



Wysong Rx

Clinical Veterinary Nutrition

Technical Monograph & Product Details

Philosophy

Design

Mechanisms of Action

Indications

Research

For every disease there is a cause.

For every cause there is a cure.

R.L. Wysong, D.V.M.

©Wysong Corporation, 2003

7550 Eastman Avenue • Midland, MI 48642 • www.wysong.net • 989-631-0009



Introduction

Philosophical Underpinnings

Nutrition is perhaps the most intimate and important of individual biological experiences. It provides the substrate from which all anatomy and physiology is derived and is a critical communication between environment and soma. When food is consumed, the external environment is literally internalized.

In our age of bounty, convenience, and self-indulgence, food is viewed more as recreation than a necessity to life and health. Most significantly, the intrusion of technology into feeding would lead us to believe that eating is complex beyond the capabilities of all but credentialed experts.

Nevertheless, this fact remains: With the exception of that infinitesimally small portion occupied by modern humans, all biota finds nutrition to be no mystery. Life itself would not exist if this were not true. All life, including the most erudite and technically sophisticated nutritionist, lives because eons of forbearers lived and had health eating what nature provided without alteration.

So yes, nutrition is important. But no, it is not complicated. (Although what follows may seem to belie this, a technical explanation is the only means to convince the technically sophisticated that something is, in actual fact, simple.)

All answers to all questions come from nature. Our sciences merely attempt to reveal what is already there. None of our knowledge is true innovation or creation, it is mere discovery. The answer to the question of what is the appropriate diet to create and maintain health therefore must lie within nature itself.

Nature reveals three characteristics of proper diet. First, it is archetypal – it is that food to which the organism is adapted in the wild setting. Second, it is optimal – its quantity and quality are sufficient to meet the biochemical individuality of the entire diverse population. Third, it is alive – food is by nature comprised of other living elements, both plant and animal.

The novel nutritional approach embodied in Wysong Rx culminates over 25 years of research to capture these essential food qualities in a packaged product.

The Archetypal Holistic Paradigm

Health is an emergent holistic quality, a gestalt of genetics and environment. Environmental factors impacting well-being include everything from temperature, light, air, altitude and humidity, to symbiotic, parasitic and pathogenic relationships, to social setting and food.

The genome, on the other hand, determines whether these environmental factors enhance or detract from health. A fish underwater thrives because water is what the fish genome expects. A human will not survive these same aqueous circumstances. The converse is true for each if the environment is changed from water to air. The genome does not adapt to dramatic environmental stress, it succumbs.

In an age where artificiality abounds, it is easy to forget these principles. Humans survive in hostile environs (from the genome's perspective) such as space and deep ocean with the aid of wondrous technology. We also survive deadly northern latitudes in the artificial environments created in dwellings. Animals taken from the wild likewise

survive domestication and caging, something their genomes did not expect. These apparent triumphs of technology over genetic constraints lead to the belief that genetic determinants are ambiguous, that anything is possible given enough technology. Of course this is not so. Although environment can modify genetic expression, this only occurs within defined limits. The more aberrant the environment, (from the specific genome's perspective), the more likely dysfunction and disease.

Survival is not synonymous with health. Looking at a fish in the first few seconds after being pulled from the water, all appears well. It's alive, robust and healthy. Same for the human submerged. One could conclude from these superficial and brief observations that air is a proper environment for fish, and water for humans. But let either of these circumstances persist and disease (dis-ease) becomes apparent – followed by death. The long-range view makes it clear that to remove a creature from its expected genetic context spells disaster. Mere immediate survival, however, makes it too easy to overlook subtle, hidden (for the moment) damage and stress, precedent to disease.

Survival under adverse environmental conditions is only a reflection of limited resiliency and adaptability. Teenagers exemplify this dramatically. They can subsist on fries and Twinkies rinsed down with pop, stay up all hours and endure the peer-pressured school and dating years, yet appear to flourish. If they become ill or are injured physically, they usually heal rapidly and completely. Eating and lifestyle *apparently* have no impact.

But that's the short view. Research has shown that wrong living in youth sets the stage for a variety of serious degenerative conditions that only emerge in later adulthood. Cancer, adult onset diabetes, atherosclerosis, obesity, arthritis, autoimmunities and dental diseases can have latency periods of decades. The smoldering fire within is merely masked by the ephemeral vitality of youth.

Youth not experiencing its proper genetic context (food being an especially important element of that context) is

just like a fish out of water or a human submerged. All that may appear well at the moment is not really so.

With these principles as a backdrop, one can look at the health-disease-food-genetic linkage and make rational judgments. What is the proper food context for a given genome? The answer: what the creature would eat and digest in the wild. For a cow it is clearly pasture. For the lion and wolf (cat and dog), prey and a few vegetable incidentals. For humans, nuts, fruits, vegetables and other creatures. This is apparent, logical and intuitive.

The food context phylogenetically determines the genome. The resultant genome in turn dictates the appropriate food. The creature cannot predate its food. Yet modern synthetic foods demand the illogic of all creatures predating their diets. (See Figure 1.)

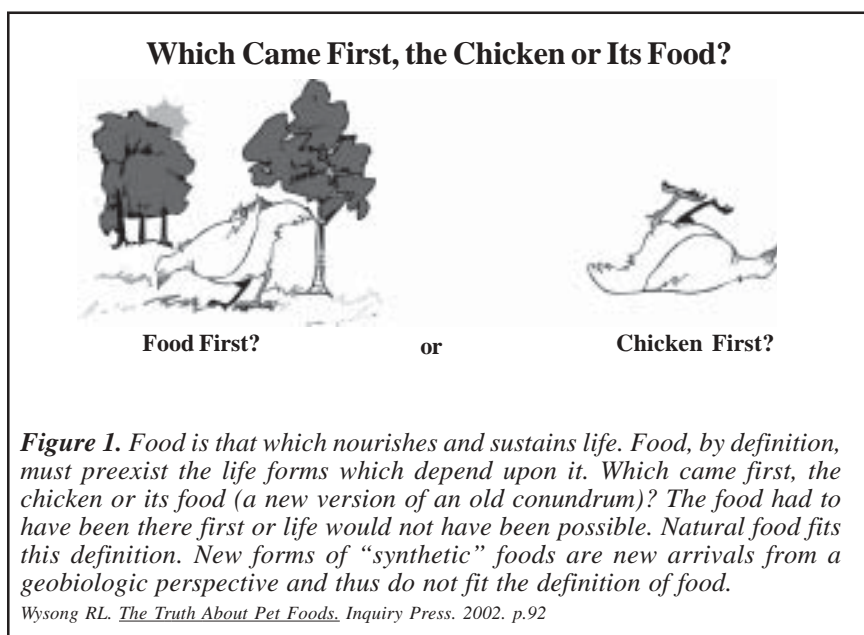

The modern era, wherein new synthetic processed foods have become the mainstay, represents but a speck of biological time on this earth. If the modern, industrial, processed food era dating back two hundred years is represented by an inch, the time during which all life consumed foods exactly as they were found in nature would be at least 276 miles! (See Figure 2.)

Remove bran from rice and the resultant thiamin-deficient white rice causes beriberi. Put people on ships

without access to fruit, and vitamin C deficiency (scurvy) results. Feed pets processed foods – in spite of meeting

dangerous about the processed pet food experiment is that such foods are foisted on the public as “100% Complete and Balanced.” Not only do pet owners feed foods an animal would never find in the wild, they do so exclusively, every day at every meal.

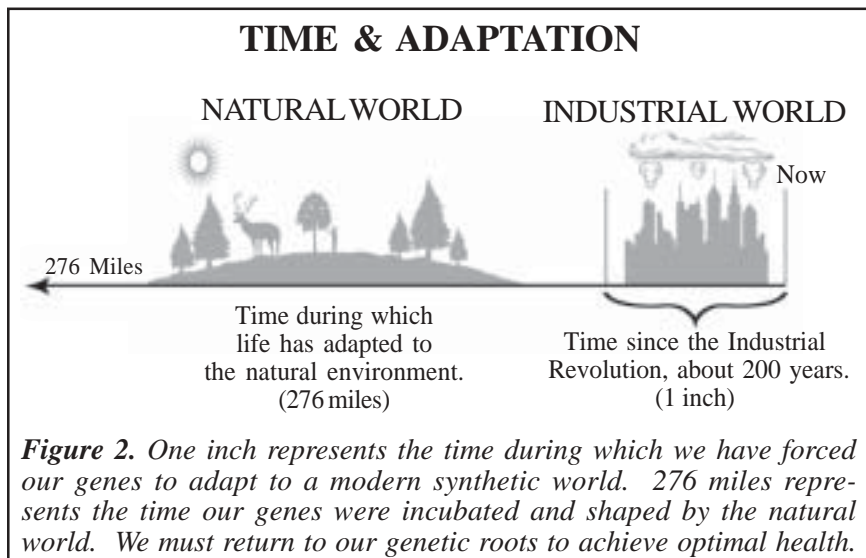

NRC guidelines and passing AAFCO feeding trials – and taurine deficient-induced dilated cardiomyopathy results. Every nutritional deficiency ever described reduces to a common theme: depart from the natural order and health is jeopardized.

be known to be 100% complete, because 100% is not known about nutrition any more than 100% is known about genetics, physics, chemistry, electronics, engineering, math and the like. It is a logical absurdity and pets and their owners pay the price. (See Figure 3.)

Although it is clear that the proper food context is that of the 276 miles, not the one inch, this is also overwhelmingly evident from the explicit and implicit conclusions of essentially all good science.

Research from the past proves environmental context must match genetic expectation if health is to prevail. Current research discoveries unveil the same self-evident theme. The future can only reveal more of the same. We are what we are and until scientists in the lab create genomes designed for foods from the lab, archetypal nutritional patterns must be respected.

The pet food industry is guilty of tagging right along behind the failed human nutritional experiment. Processed pet foods are just another version of Fruit Loop technology. But what is more

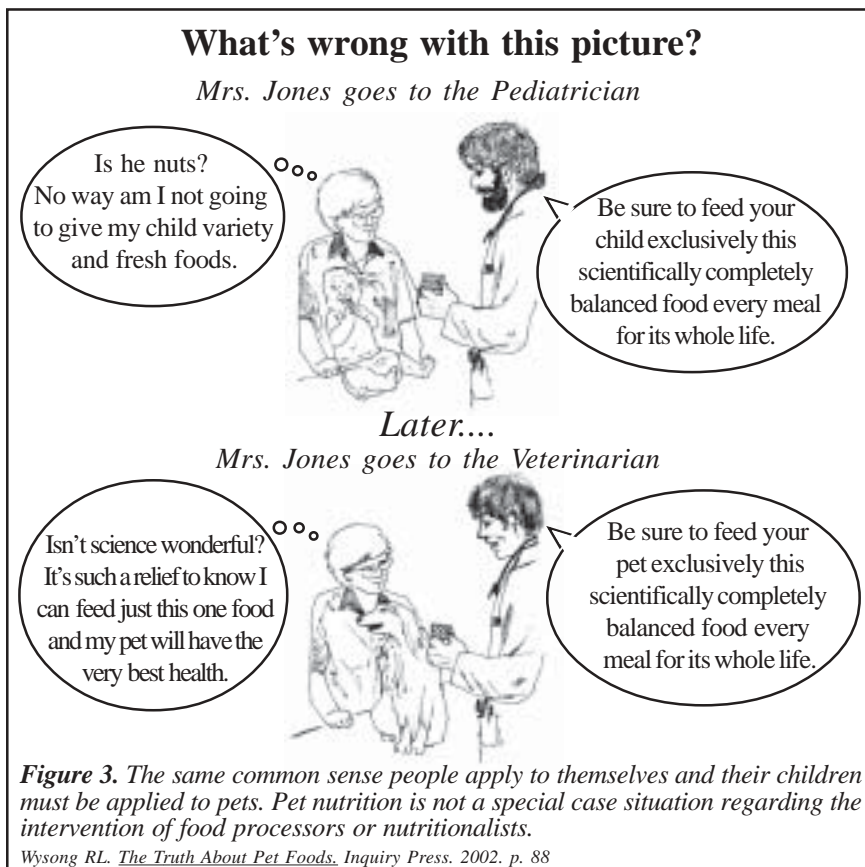

The true 100% complete food is only that food which the creature is genetically adapted to, food as it is found in the wild, without manipulation.

“100% completeness” emerges really only as a point of concern since the food supply has become synthetic and fractionated. Yes, retorters, extruders, ovens, dehydrators, freezers, synthetic vitamins and the like are wondrous inventions. But their necessity is linked primarily to commercial – not health – interests. They enable the conversion of indigestible and toxic foods (such as raw grains and legumes) into edible preparations with increased shelf life, enabling profitable food distribution. Since such foods are really experimental, and always accompanied by continuing nutritional consequences, a huge scientific industry has become necessary to analyze and test products in an attempt to fortify them back to their original value.

But the emergent, holistic, healthy value of natural foods cannot be reductionistically understood nor regained by analysis and reassembly of parts, any more than the emergent holistic qualities of water can be predicted or understood by analysis of the quantum properties of hydrogen and oxygen. No scientist has a clue why, when hydrogen and oxygen combine, a liquid is created that is “wet” and expands when frozen. Likewise there is not a clue within the millions of chemical nutrients within food that would predict holistic qualities such as immune resistance, longevity, mood or strength.

A thorough analysis of the scientific literature over the past 25 years has proven these assertions to be unassailable. Time will only confirm further that to the degree we remove a creature from its proper environmental context, including its food, health will be lost proportionately. It is therefore totally predictable, and increasingly confirmed in clinical trials and meta-analyses, that essentially every health condition is impacted by nutrition. What’s more, some of the more enigmatic idiopathic conditions such as atherosclerosis, cancer, obesity, adult onset diabetes, digestive disturbances, allergies, autoimmunities, dermal conditions, pancreatitis and dental disease may not be so mysterious after all. We need look no further than the food plate or bowl to find the disease vector in the form of synthetic and fractionated food components fed monotonously and relentlessly. All of these degenerative conditions are nothing more than pleomorphic manifestations of the same underlying etiology-genetic discordancy.

Addressing this nutritional crisis should be a paramount concern in medical practice. Surely preventing such conditions is far superior to palliative symptomatic care, which is the only present option.

Nutrigenomic Optimal Nutrition

Scientific advance has confirmed that the relationship between genotype (health potential) and phenotype (health realization) is intrinsically linked with critical environmental modifiers. With respect to the modifier – food – a new science – nutrigenomics – has emerged. This science studies the impact single nucleotide polymorphisms (SNPs – pronounced snips) and multiple SNPs (Haplotypes) have on diet, and conversely how diet can modify genetic expression.

Genetic research has reached a state of precision where single genes have been identified for production of nutritionally important enzymes and other proteins, transport molecules which ferry nutrients and cofactors, and numerous other molecules responsible for digestion, metabolism, utilization and control of both macronutrients and micronutrients. (See Figure 4.)

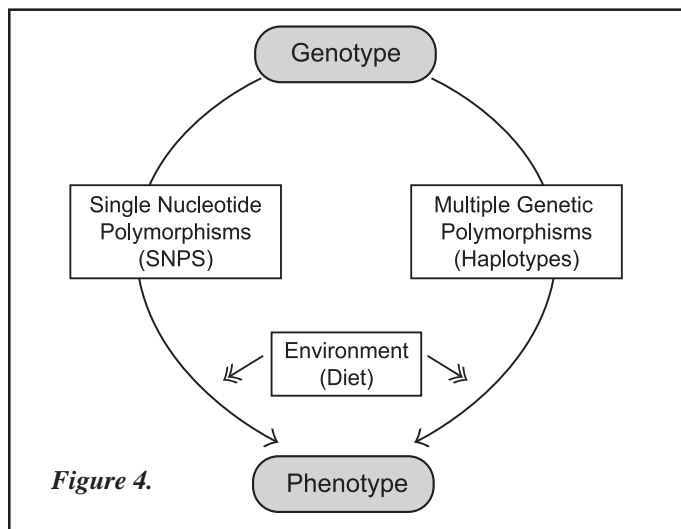

Figure 4.

Well over a thousand human disease genes have been characterized and many of these are monogenic. Examples include sickle cell anemia (a single amino acid that reduces hemoglobin’s affinity for oxygen), phenylketonuria (a mutation in phenylalanine hydroxylase leading to toxic levels of phenylalanine), hypertension (a variant of the angiotensinogen gene), cardiovascular disease (AG to A transition in the HDL promoter APOA1 gene as well as genetically controlled C-reactive protein, homocysteine

and vitamin C synthesis, among others), cancer (C667T polymorphism and methylenetetrahydrofolate reductase gene relation to folate, vitamin B₁₂, B₆, and methionine), and diabetes (Pro 12A1a polymorphism in the peroxisome proliferator activator receptor). Parallels exist in animals. This is not to say disease is inevitable, but rather there is a susceptibility that will only be manifest if the diet is not matched properly to the genome.

On the other hand, dietary factors can directly bind to receptors and modify gene expression/enzyme synthesis. Altering the concentration of enzymes (encoded by SNPs) alters the flux in pathways that in turn impacts physiology.

In other words, genes affect the response to diet, and diet affects the expression of genes. The system is myriad feedback loops and holistic – not linear or reductionistic. (See Figure 5.)

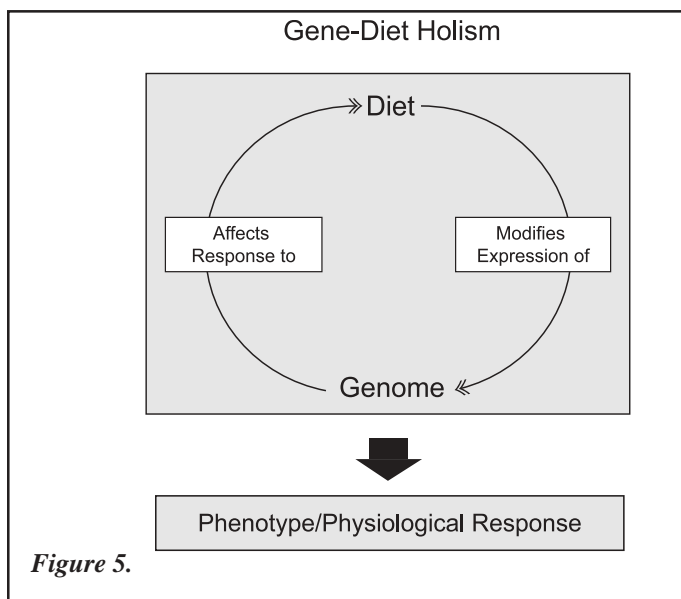

If all were known about such nutrigenomic interactions, a food could be properly constructed from parts. But all is not known for even one individual, let alone all others with their individual SNP personalities. Our knowledge is a drop – our ignorance a sea.

Although a species may be 99.9% genetically identical, the remaining 0.1% polymorphisms make a tremendous difference in phenotypical health. Polymorphism is yet another proof that one nutritional size does not fit everyone. Nutritional research has demonstrated the same proof, but the tails of the bell curve are ignored in setting official dietary

recommendations or “100% complete” standards. A biochemical flux through a metabolic or signal transduction pathway is not the same for all. This explains the bell curve phenomenon and biochemical individuality in nutrition: why a single defined diet may exceed the needs of some and be insufficient for others. (See Figure 6.)

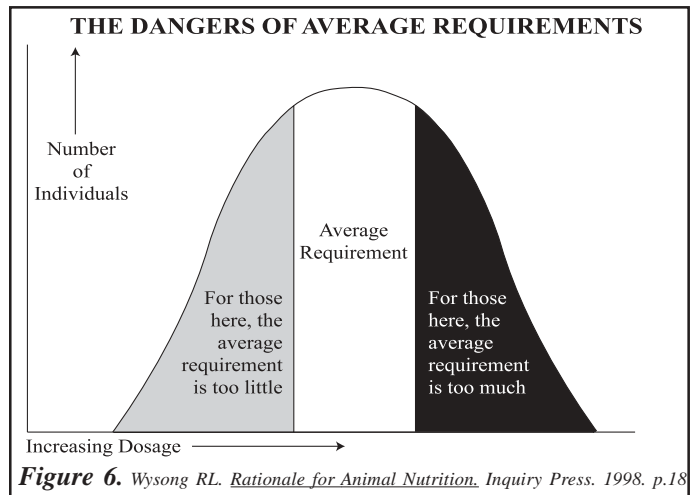

Figure 6. Wysong RL. *Rationale for Animal Nutrition*. Inquiry Press. 1998. p.18

Biochemical individuality is best addressed by optimizing the diet. This is a different set point than in common nutritional practice where isolated nutrients are tested to determine the levels necessary to prevent overt deficiency or toxicity. Chronic undernutrition can create idiosyncratic manifestations far removed in time from that of a short-term feeding trial. Virtually every modern chronic degenerative disease has a nutritional etiology, yet this causation remains totally undiscovered by short-term, feeding-trial, classical, nutritional research. (See Figure 7.)

Will optimal nutrition therefore come from further genetic mapping and nutrigenomic discovery? Such technology will certainly help define disease caused by mutational idiosyncrasy. But for the majority of the population, SNPs and all, the holistic bounty of the natural archetypal diet is the best assurance of optimal nutrition. Optimal nutrition is the best assurance of optimal health. If health is lost, optimal diet is the best hope of restoration. Wysong R_x (WR_x) is a veterinary-exclusive line specifically designed to mimic the archetypal holistic qualities characteristic of true natural food.

Food Is Alive By Definition

Long ago when biological science was in its infancy, debate raged as to whether life spontaneously emerged from nonliving matter. But spontaneous generation was

Biochemical Individuality

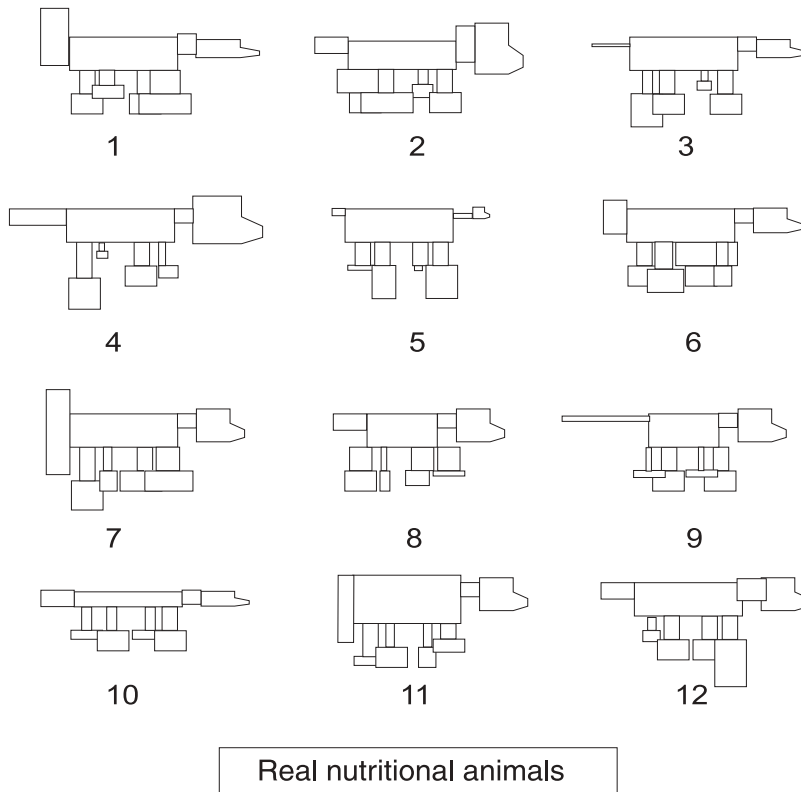
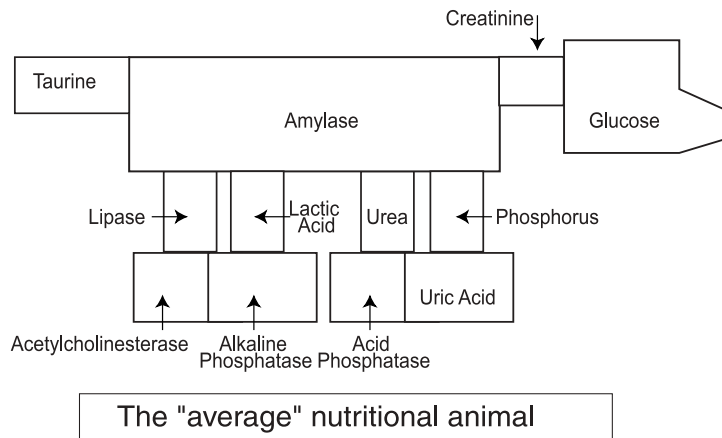

Figure 7.

Average nutritional requirements presume there is an average animal and that one "size" fits all. In reality, no two individuals are alike in either appearance or in terms of biochemical parameters. The top drawing represents an animal as depicted by average nutrition. The bottom drawings represent the variety, the biochemical individuality, of the real world. Feeding all creatures with one prescribed diet cannot meet demands. What is optimal for one may be excess or inadequate for another.

life can come from non-life, it has never been found to have exception. That is what makes it a law as sure as the laws of gravity and motion.

A corollary of this law (defined by Wysong in the early 1980s) is the Law of Nutri-biogenesis. Using the principle of Bio-genesis it argues that life in its optimal healthy state can only come from living food. Life be-gets life. The proof of this law is in its logic and the empiricism that follows it without fail. (See Figure 8.)

If dead or in-organic matter cannot spontane-ous-ly generate life, how could such lifeless matter form or sustain the health of life? There is a transition between non-life and life that is not bridged spontaneously.

Virtually every modern disease is incited or aggravated by the consumption of lifeless food fractions. All of the nutritional discovery linking diet

soon disproven. In its place emerged the Law of Biogenesis. Simply, this law states that life only comes from preexisting life. Although this law has been ignored by modern scientific endeavor that still seeks to prove

to health is ultimately reducible to violation of the Law of Nutri-biogenesis. Why is free radical pathology now thought to underlie virtually all disease? Insufficient antioxidant nutriture, and increased oxidant consumption

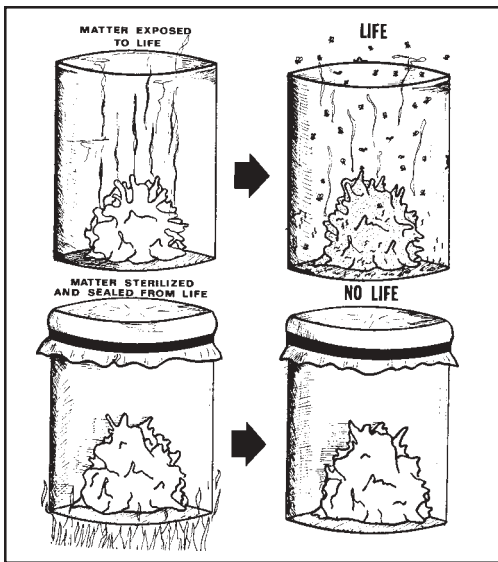

Figure 8. Organic material exposed to bacteria, fly eggs, fungal spores, etc., may generate populations of life. Superficially it appears as though life is coming from the matter itself. However, as shown by Redi, Pasteur and Spallanzani, if matter is sterilized and then sealed from possible biological contamination, no life arises. Thus, there is no spontaneous generation, only biological reproduction according to kind – biogenesis.

Wysong RL. *The Creation-Evolution Controversy*. Inquiry Press. 2003. p.181

from dead devitalized foods nutrient stripped and oxidized in processing is the answer. Why are omega-3 fatty acids linked to a host of immune-related diseases as well as most other degenerative diseases? Dead, devitalized, nutrient-stripped, archetypically inappropriate and oxidized foods is the answer. Why do carnitine, taurine, folate, mineral and other vitaminic and amino acid deficiencies occur? The killing and nutrient stripping of modern foods is the answer.

To be living, it is understood that a food must be in its holistic state and not heated much above body temperature (not more than 118° F). It thus retains its inherent enzymes intact. A raw apple is better than pasteurized apple cider. Raw milk is better than pasteurized homogenized milk. Raw meat is better than its fried counterpart. (See Figure 9.)

Life is almost infinitely complex, it is the epitome of the ordered state. But fire is the enemy of order. Fire turns a simple structure such as a home into random ashes. Fire even more completely decimates life and its characteristic order. This occurs in keeping with another important law in science, The Second Law of Thermodynamics. (See Figure 10.)

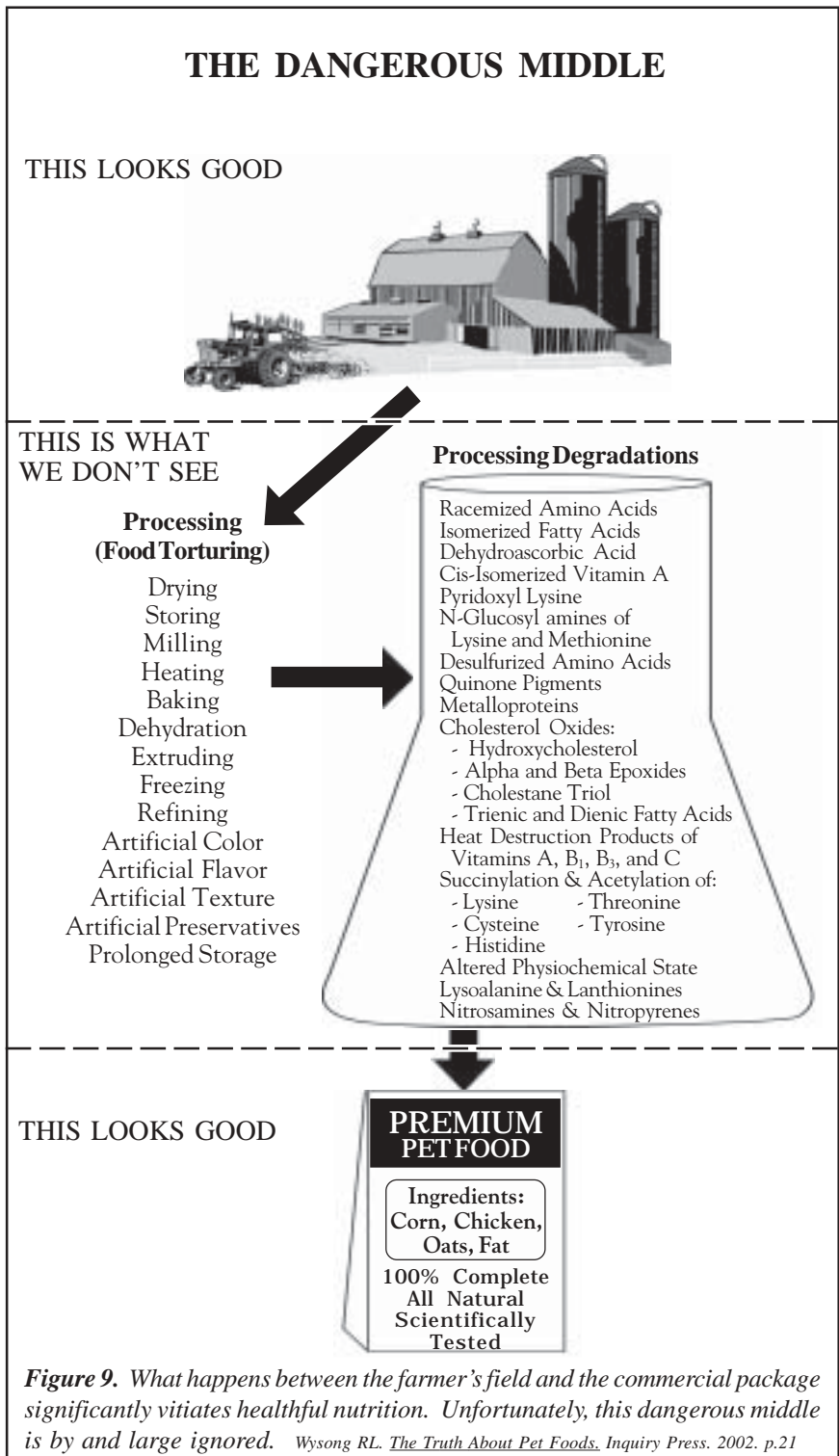

Figure 9. What happens between the farmer's field and the commercial package significantly vitiates healthful nutrition. Unfortunately, this dangerous middle is by and large ignored. Wysong RL. *The Truth About Pet Foods*. Inquiry Press. 2002. p.21

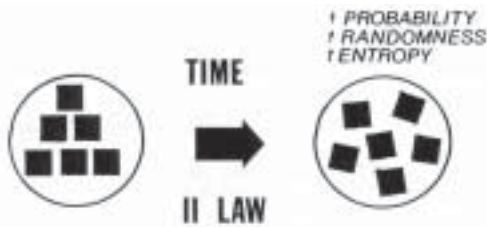

Figure 10. Wysong RL. *The Creation-Evolution Controversy*. Inquiry Press. 2003. p. 243

Fire accelerates the inevitable increase of entropy, the loss of order and increase in randomness. How then can we expect food – that has in essence been turned to ashes – to create the low entropic ordered state of health? (Arguments about open and closed systems could be made by physicists, but for the purpose of this brief, polemic principles are being highlighted.) Would we not expect a better result from foods that have retained the low entropy of their living state and can hope to pass such order on to the eater? Would we not expect a better result from foods that have not been rushed along by processing, toward their lifeless entropic end?

The vitiation of nutritional quality as a result of high heat processing is only matched by the abundance of toxins produced. Although high heat processing enables the creation of an endless variety of food trinkets, permits stable shelf life, freedom from pathogens, easy distribution and higher profits for producers, it violates the Law of Nutriogenesis. Profits go to the producers, disease goes to the consumers.

The true challenge in modern food production, if health is the goal, is fresh untainted food that does not violate the Law of Nutriogenesis. That challenge has been met successfully with Wysong R_x .

Wysong R_x Technology

For many years Wysong has understood the seriousness of these fundamental feeding/health issues and formulated foods based upon the above principles. Considerable effort has also been expended to educate pet owners about archetypal feeding concepts and how they can improve nutritional conditions with fresh foods, supplements and varied feeding.

Important advances in processing and formulation can bring foods as close as possible to what the animal’s genome expects and can thrive on. The Wysong beginning

premise, unlike that of industry convention, is that any formulated processed food is inferior to the natural raw diet regardless of fortification, analyses or short-term feeding trials. The manufacturing goal should therefore be to stretch toward the ideal natural diet rather than rest on the laurel of “100% completeness.”

Wysong R_x is a significant advance toward the ideal and incorporates a variety of new technologies to achieve highly palatable natural nutrition while providing specific nutraceuticals with proven metabolic effects. The Wysong R_x objective is to reintroduce a pet to its real food, the panoply of nutrients the genome expects, and shift the balance from disease and immunological weakness, to robust optimal health. Innovations include non-heat processing, bacterial and parasitic control, probiotic, prebiotic (synbiotic) and enzymatic augmentation, immune enhancement, natural antioxidant protection and nutraceutical bioactivation.

Meat-Organ-Bone Base

The natural archetypal food of the carnivore is meat, organs and bones.

This is the predominant base (devoid of grains, common to virtually all processed pet foods) in Wysong R_x and cannot be surpassed in terms of the essential amino acid profile and other inherent macronutrient and micronutrient merits. The unusual palatability speaks to the animal’s innate sense of nutritional value.

| Taurine Content of Selected Foods (MG/KG, Wet Weight) | | |
|---|----------------------|--------------------|
| Item | Uncooked Mean | Boiled Mean |
| Beef muscle | 362 | 60 |
| Beef liver | 192 | 73 |
| Beef kidney | 225 | 76 |
| Lamb muscle | 473 | 126 |
| Lamb kidney | 239 | 51 |
| Pork muscle | 496 | 118 |
| Pork liver | 169 | 43 |
| Chicken muscle | 337 | 82 |
| Cod | 314 | 161 |
| Oysters | 698 | 89 |
| Clams | 2400 | 446 |

Taurine presents an excellent example of nutrient loss due to processing. Thousands of animals have suffered taurine deficient diseases such as dilated cardiomyopathy as a result of the processing loss of this nutrient.

Figure 11.

Non-Thermal Processing

Through flash freezing and dehydration, Wysong R_x retains all of the raw natural attributes while remaining exceptionally shelf stable. There is no better way known at present to preserve natural nutritional value. (See Figure 11.)

On the other hand, the toxic burdens presented by singular feeding of heat degraded processed foods may tip the scales in the wrong direction for the ill or immune-compromised animal, and thwart recovery.

Pathogen control

Specific natural ingredients in Wysong R_x and special low temperature processes help to inhibit potential food-borne pathogens without sacrificing nutritional quality or introducing synthetic antimicrobials. Pathogen-active ingredients include lactoferrin and lactoperoxidase, special fruit components, and antiparasitic phytoplankton mineral matrices.

• Lactoferrin

Lactoferrin (LF), particularly concentrated in plasma and dairy whey, is a bilobular glycoprotein containing N-acetyl D glucosamine, N-acetylglucosamine, galactose, fucose, mannose, neuraminic acid, and a polypeptide chain of 689 amino acids configured into 25 helices, 32 sheets and 58 turns with two binding sites for ferric ions (Fe³⁺) and bicarbonate. It is closely related in structure to the plasma ion transport protein, transferrin. If the molecule is not saturated with iron it is apolactoferrin, if saturated it is hololactoferrin. (See Figures 12, 13 and 14.)

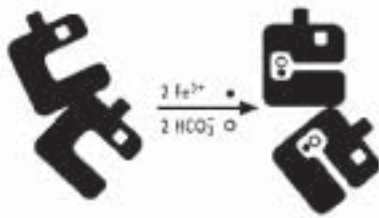

Figure 12. Iron-binding mechanism of lactoferrin.

LF is found in all epithelial exocrine secretions bathing mucous membranes and is present in saliva and tears, bronchial, nasal, bile and pancreatic secretions, milk, colostrum, semen, cervical mucus, urine, and is also synthesized by neutrophils. It is a first line of defense.

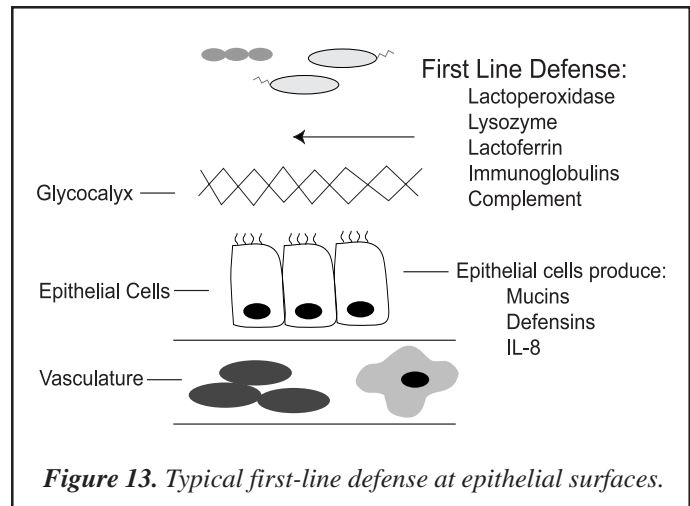

Figure 13. Typical first-line defense at epithelial surfaces.

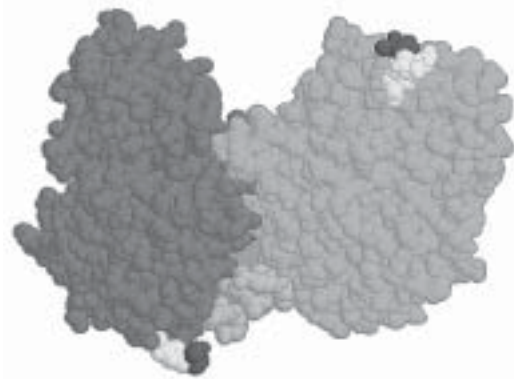

Figure 14. Bilobed lactoferrin molecule containing two binding sites for Fe³⁺

LF can sequester iron from bacterial pathogens resulting in a bacteriostatic effect. Its highly positively charged N-terminus region can also bind to lipopolysaccharides on bacterial cell walls, increasing permeability and resulting in a bacteriocidal action. Additionally, LF can bind to viral envelope protein, preventing fusion to cells by shielding the binding domain.

LF immunomediator activity includes:

- ④ Release of neutrophil-activating interleukin 8
- ④ Production of other interleukins
- ④ Antibody synthesis
- ④ Lymphocyte proliferation
- ④ Complement activation
- ④ T-cell proliferation
- ④ Protective function over macrophages and lymphocytes
- ④ Activation of natural killer cells
- ④ Induction of colony-stimulating activity

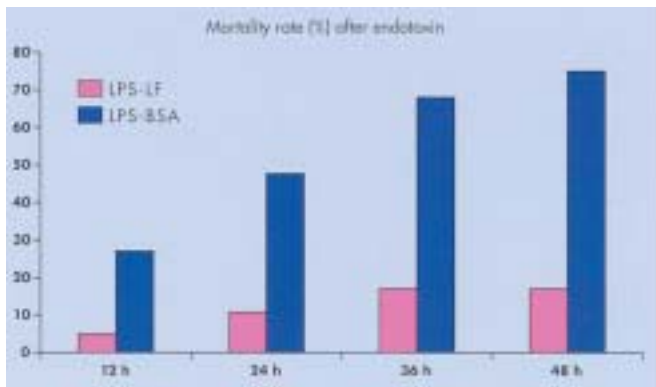

Figure 15. Oral feeding with bovine Lactoferrin protects germ-free piglets against endotoxins (i.v. LPS) (Lee W.L. et al. 1998. The protective effects of lactoferrin feeding against endotoxin lethal shock in germfree piglet, *Infect & Immun* 66 (4), 14. 1421-1426)

- ④ Activation of leukocytes and monocytes
- ④ Potentiation of macrophage cytotoxicity
- ④ Maturation of splenic B cells
- ④ Upregulation of CD4 lymphocytes and NK cell activity
- ④ Protection of lymphocytes against free iron
- ④ Secondary granule activity in polymorphonuclear leukocytes
- ④ Regulation of myelopoiesis
- ④ Inhibition of granulopoiesis
- ④ Production and release of cytokines such as TNF- α , IL-1 β , NO, and GM-CSF

LF is probiotic by inhibiting pathogens and stimulating beneficial gut flora. (Surprisingly, LF is pathogen-selective, leaving beneficial flora intact.) Clinical data have demonstrated a protective effect against *Haemophilus influenza*, chronic hepatitis C, *Helicobacter pylori* (cancer- and ulcer-inducing bacterium), fungal infections such as *Candida* and *Tinea pedis*, *E. coli*, *Salmonella*, *Staphylococcus*, and *Listeria*.

LF also seems to work in synergy with antibiotics. One study showed that *E. coli* toxin challenge resulted in 74% mortality in controls and 17% in LF subjects. In another study, kidney infections were reduced by 40-60% and bacterial counts 5-12 fold.

As a free iron scavenger, apo-lactoferrin helps prevent oxidation and free radical formation. (Iron is a strong oxidizer.) As such, DNA repair mechanisms are protected, thus enhancing health, slowing the aging process and serving to combat neoplasia. LF can transport iron and release it

at specific receptor cells in the colon where it is readily absorbed. As both a scavenger and iron donor, LF helps regulate iron nutrition, contributing or removing iron as cellular circumstances dictate. (See Figure 16.)

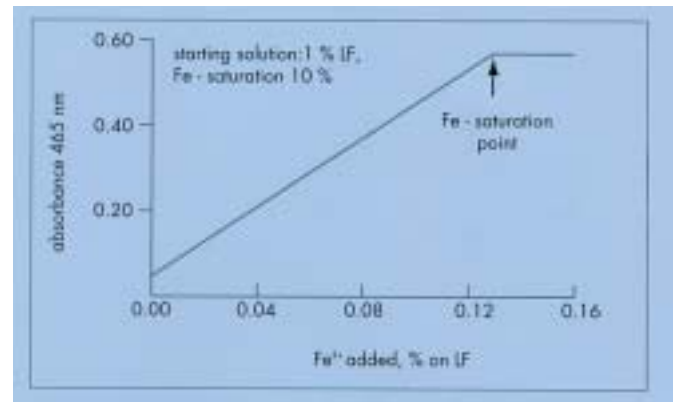

Figure 16. Iron (Fe^{3+}) binding activity of lactoferrin (DVM International, 1996).

• Lactoperoxidase

Lactoperoxidase (LPO) is an abundant enzyme in milk, whey fractions and other exocrine secretions such as tears and saliva. LPO is a complex glycoprotein containing an iron-bound heme and a chelated calcium ion. It, like LF, serves as a first line of defense.

LPO is both bacteriostatic and bactericidal. Gram negative, catalase positive organisms are more readily inhibited by LPO than are gram positive, catalase negative bacteria. Gram negative, catalase positive organisms, (coliforms, salmonella, etc.) are not only inhibited, but are killed if sufficient hydrogen peroxide is provided – chemically, enzymatically or by hydrogen peroxide-producing microorganisms. On the other hand, the action of lactoperoxidase against gram-positive organisms is generally bacteriostatic and not lethal.

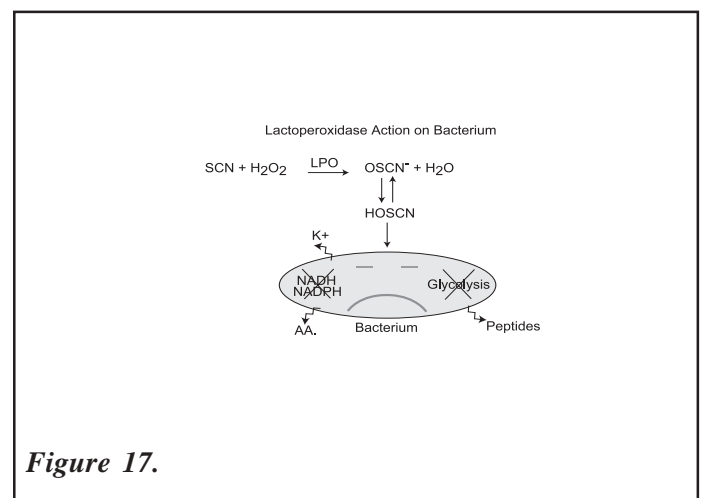

Figure 17.

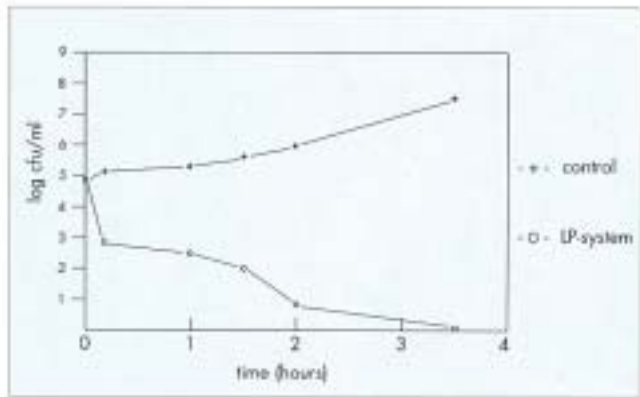

Figure 18. Bacterial effect LP-system on enteropathogenic *E. coli* in a milk product (*DVM International, 1966*).

LPO exerts its antimicrobial action by catalyzing the oxidation of thiocyanate ions (SCN⁻) to hypothiocyanate (OSCN⁻) an anion in equilibrium with hypothiocyanous (HOSCN) acid. HOSCN is the mediator in bacterial killing, being cell permeable and capable of oxidizing sulfhydryl groups in enzymes, thus inhibiting glycolysis as well as NADH/NADPH dependent reactions. The sulfhydryl groups in bacterial cytoplasmic membranes are also oxidized, resulting in the loss of the ability to transport glucose and leaking of potassium ions, amino acids and peptides. Remarkably these cytotoxic effects occur without damage to host cells. It is theorized that some disease states characterized by chronic bacterial infection may be due to a breakdown of this lactoperoxidase system at mucosal interfaces. (See Figure 17.)

LPO acts synergistically with LF and secretory immunoglobulins in Wysong R_x formulations to stabilize shelf life and exert *in vivo* antibacterial effects.

• Natural Mineral Matrix

A special Wysong R_x composition of desiccated sea plankton exoskeleton matrices contributes both nutritional and antiparasitic activity.

Two grams of these 5-20 micron porous particles have a surface area equal to a football field. By separating nutrients it also increases enzymatic efficiency. When in contact with parasites it can

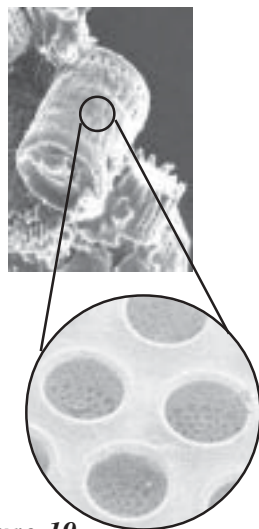

Figure 19. Desiccated Sea Plankton

disrupt outer cuticle membranes resulting in their desiccation and death.

• Fruit Extracts

Certain fruits have remarkable antioxidant and antimicrobial activity without attendant toxicities characteristic of synthetic additives. WR_x fruit extract contains malic acid, sorbitol, phenolic antioxidants such as chlorogenic and neochlorogenic acids and an array of other nutritionally beneficial components.

Incorporation of this ingredient in WR_x provides excellent product protection and nutraceutical benefits. (See Figures 20, 21 and 22.)

Antioxidant Properties of Fruits and Vegetables

| | ORAC Value*/100 g |
|-----------------------|-------------------|
| Prunes..... | 5770 |
| Raisins..... | 2830 |
| Blueberries..... | 2400 |
| Blackberries..... | 2036 |
| Kale..... | 1770 |
| Strawberries..... | 1540 |
| Spinach..... | 1260 |
| Raspberries..... | 1220 |
| Brussels Sprouts..... | 980 |
| Plums..... | 949 |
| Alfalfa Sprouts..... | 930 |
| Broccoli Flowers..... | 890 |
| Beets..... | 840 |
| Oranges..... | 750 |
| Red Grapes..... | 739 |
| Red Bell Pepper..... | 710 |
| Cherries..... | 670 |
| Kiwi Fruit..... | 602 |
| Grapefruit, pink..... | 483 |
| Onion..... | 450 |
| Corn..... | 400 |
| Eggplant..... | 390 |

*ORAC (Oxygen Radical Absorbance Capacity) measures a food's ability to subdue oxygen free radicals by comparing its absorption of peroxy or hydroxyl radicals to that of a water-soluble vitamin E analog. (*USDA Human Nutrition Research Center on Aging Tufts University, Boston*)

Figure 20.

Oxidative Malonaldehyde Measures

| Day | Control mg malonaldehyde/kg sample | Wysong Fruit Extracts mg malonaldehyde/kg sample | BHA/BHT mg malonaldehyde/kg sample |
|-----|---------------------------------------|---|---------------------------------------|
| 0 | 0.263 | 0.170 | 0.188 |
| 7 | 0.669 | 0.249 | 0.275 |
| 14 | 0.617 | 0.231 | 0.149 |
| 21 | 0.680 | 0.197 | 0.187 |
| 28 | 0.419 | 0.287 | 0.178 |
| 30 | 0.741 | 0.284 | 0.292 |
| 60 | 0.839 | 0.544 | 0.425 |

Over the course of 60 days, samples were tested with the 2-thiobarbituric acid test, which expresses lipid oxidation in mg of malonaldehyde per kg of sample. The higher the malonaldehyde content, the greater the extent of oxidative deterioration of lipids.

Figure 21.

Pathogen Inhibition

| Treatment | Day | Total count (log cfu/g*) | <i>Salmonella</i> <i>typhimurium</i> (log cfu/g) | <i>Escherichia</i> <i>coli</i> 0157:H7 (log cfu/g) | <i>Listeria</i> <i>monocytogenes</i> (log cfu/g) | <i>Yersinia</i> <i>enterocolitica</i> (log cfu/g) | <i>Staphylococcus</i> <i>aureus</i> (log cfu/g) |
|-----------------------|-----|-----------------------------|--|--|--|---|---|
| Control | 0 | 4.84 | 4.17 | 4.18 | 3.68 | 3.67 | 3.76 |
| Wysong fruit extracts | 0 | 5.12 | 4.39 | 4.44 | 4.11 | 3.97 | 4.06 |
| Control | 1 | 6.29 | 4.85 | 5.34 | 3.76 | 5.57 | 4.18 |
| Wysong fruit extracts | 1 | 6.40 | 4.56 | 4.66 | 3.82 | 4.64 | 4.03 |
| Control | 3 | 7.46 | 4.67 | 7.09 | 3.40 | 6.50 | 4.39 |
| Wysong fruit extracts | 3 | 7.20 | 4.36 | 5.48 | 3.26 | 4.91 | 3.68 |
| Control | 5 | 9.81 | 5.58 | 7.20 | 4.63 | 7.90 | 5.25 |
| Wysong fruit extracts | 5 | 7.33 | 4.28 | 6.15 | 4.06 | 5.04 | 4.14 |

*log colony-forming units/gram

The above table illustrates the inhibitory effects of Wysong fruit extracts on pathogens in fresh ground beef. For each of the pathogens tested, after five days the treated samples contained fewer microorganisms than the control samples.

Figure 22.

Synbiotics (Prebiotics and Probiotics)

Prebiotics are saccharide food components not digested by the host but which proceed intact to provide a food substrate for the selective growth of probiotic organisms. Garlic, yeast culture and other oligosaccharides in WR_x are prebiotic. Probiotics are host-friendly bacteria that exert a multitude of immune stimulating, digestive, nutritional and antipathogenic effects. Active WR_x probiotic cultures mimic the probiotic-rich viscera of the prey animal. (See Figure 23.)

Enzymes

Natural foods not heated above approximately 118°F contain enzymes that can aid in the digestion of food. WR_x contain these natural food enzymes and supplemental enzymes as well. This spares digestive and pancreatic exertion. Since digestion is one of the most strenuous metabolic acts, easing this stress is particularly beneficial to the compromised animal. (See Figure 24.)

Beneficial Effects of *Enterococcus faecium*:

1. Fermentation of carbohydrate to lactic acid, thus lowering gastrointestinal pH and discouraging pathogenic growth.
2. An increase in palatability of the food it is found in and growth stimulation.
3. Production of antitoxins, which help to neutralize enterotoxins from *E. coli*.
4. Production of hydrogen peroxide, which has a bacteriocidal effect on anaerobic microorganisms.
5. Production of a metabolite that has specific activity against *E. coli*.
6. Production of antibiotics and bacteriocins, such as acidophylin, acidolin, lactalin, and nisin. These act against a variety of pathogenic species such as *S. proteus*, *P. aeruginosa*, *B. subtilis*, *Salmonella*, *Shigella*, and *Clostridium*.
7. Change in the re-dox (oxidation-reduction) potential, thus creating an unsuitable environment for the aerobic pathogenic microorganism.
8. Crowding out of the other microorganisms by implanting on the mucous surfaces and villi, thus decreasing the coliform count.
9. A low sensitivity to most common antibiotics. May be used safely in combination with: Aureomycin, Oxytetracycline, Bacitracin, Lincomycin, ASP-250, Furacin, Carbodox (Mecadox), and Virginiamycin. Proven to be sensitive to: Ampicillin, Tetracycline, Spectinomycin, Novobiacin, and Gentacin.
10. Inhibition of bacteria that degrade intestinal protein to non-utilizable forms.

Figure 23.

Pancreatic Size

| Species | Pancreas Weight as a Percentage of Body Weight |
|--------------------------|---|
| Wild Mice | 0.32 |
| Mice on a Processed Diet | 0.84 |
| Rats on a Raw Diet | 0.32 |
| Rats on a Processed Diet | 0.84 |



Figure 24. Enzyme-devoid processed foods cause enlargement (disease) of the Pancreas

*This experiment was designed to determine the pancreatic weight differences between various species of mice.

Antioxidation

Free radical pathology underlies most disease. Oxidation of food components can significantly contribute to the body's free radical load, a load that is already excessive in disease states. Additionally, valuable fatty acids such as omega 3, 6, and 9 can be damaged – creating eicosanoid deficiency, imbalance and toxic end products. WR_x contain several natural antioxidants such as vitamins C and E, carotenoids and flavanoids, organic acids to

chelate prooxidant metals, and plant phytochemicals. In addition, fats are micropurged of oxygen by special nitrogen injection. (See Figures 25 and 26.)

WR_x is designed to provide metabolic antioxidant protection as well as protection of nutrients within the package. (See Figure 27.)

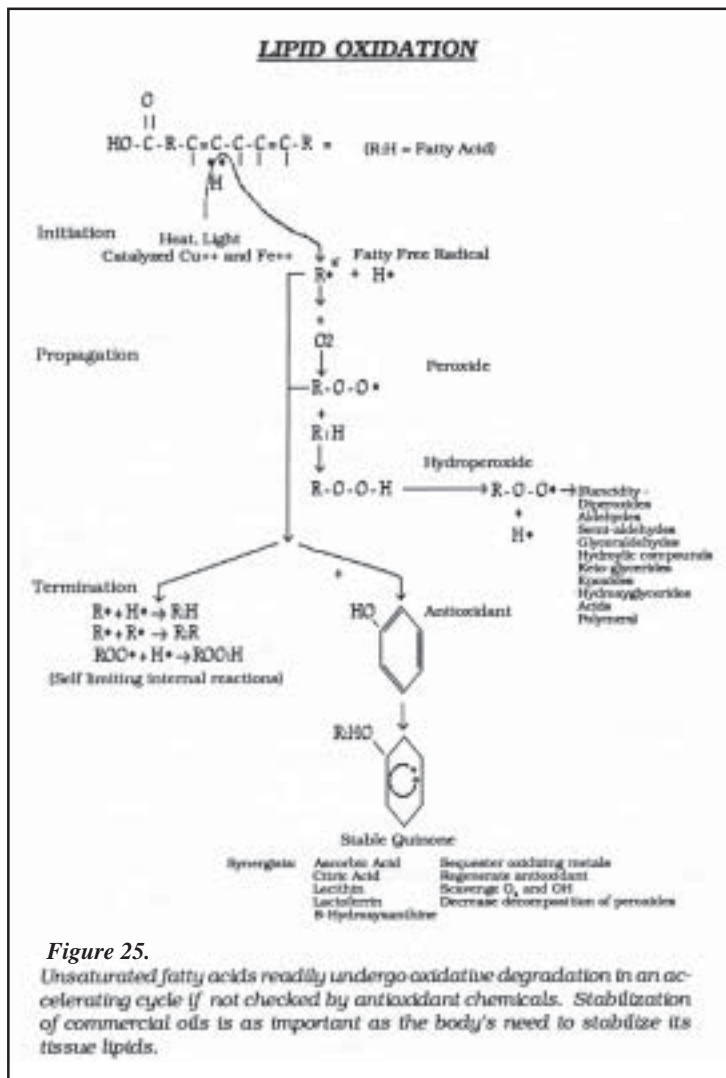

Figure 25. Unsaturated fatty acids readily undergo oxidative degradation in an accelerating cycle if not checked by antioxidant chemicals. Stabilization of commercial oils is as important as the body's need to stabilize its tissue lipids.

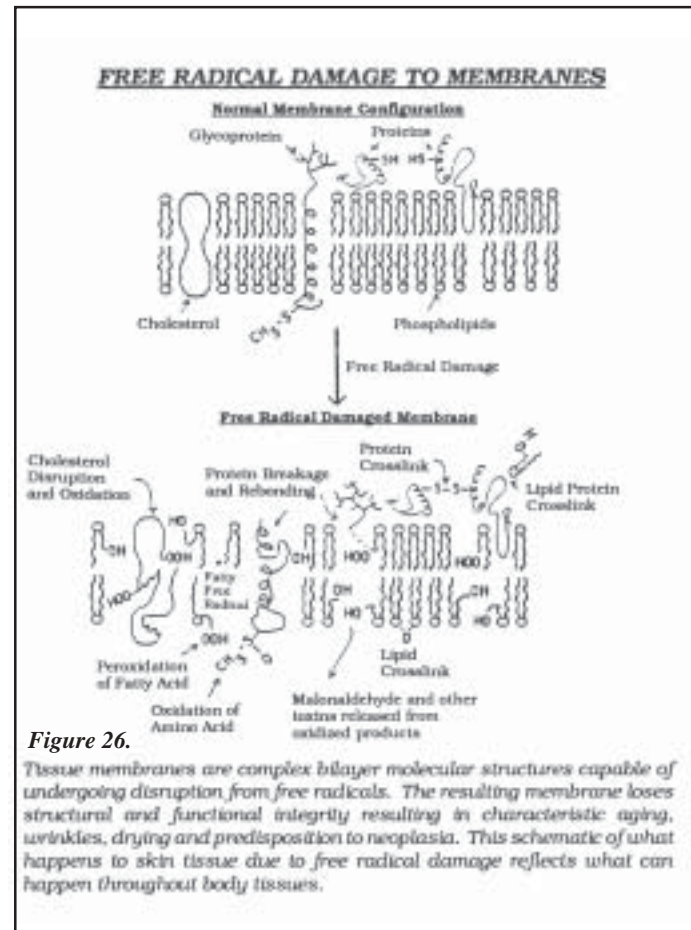

Figure 26. Tissue membranes are complex bilayer molecular structures capable of undergoing disruption from free radicals. The resulting membrane loses structural and functional integrity resulting in characteristic aging, wrinkles, drying and predisposition to neoplasia. This schematic of what happens to skin tissue due to free radical damage reflects what can happen throughout body tissues.

Nutraceuticals

Nutraceuticals are active foods, or components of natural foods, with specific beneficial metabolic effects. Unlike pharmaceuticals, their contraindications are practically nil if used within reason. This is due to the fact that natural substances are part of biological experience (as opposed to synthetics) and metabolic pathways are in place to both utilize their benefits and detoxify noxious elements. Although nutraceutical effects are not as immediately dramatic as pharmaceuticals, they help address underlying causes and work with the body's own healing mechanisms rather than merely masking symptoms.

The special combination of the non-thermally processed meat-organ-bone base, combined with specific scientifically validated nutraceuticals and other micronutrients provides the clinician an excellent and readily (even eagerly) accepted treatment option as an adjuvant to conventional therapy.

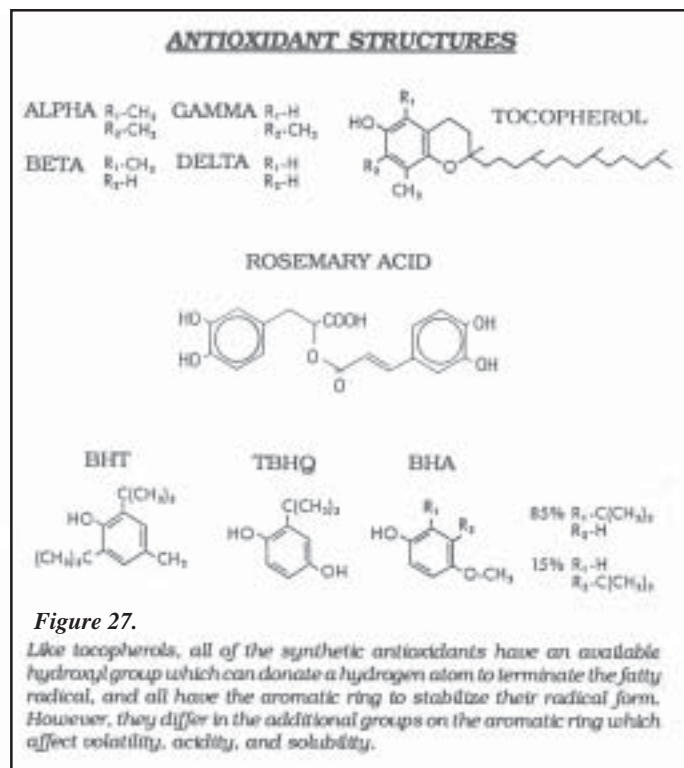
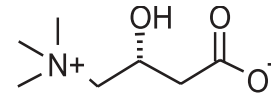

Figure 27. Like tocopherols, all of the synthetic antioxidants have an available hydroxyl group which can donate a hydrogen atom to terminate the fatty radical, and all have the aromatic ring to stabilize their radical form. However, they differ in the additional groups on the aromatic ring which affect volatility, acidity, and solubility.

The following, in brief, describes the biochemical activity of specific nutraceuticals with substantiated effects. For further investigation and details of proofs, see the references listed in each of the individual R_x formulations. (see pp 29 - 63)

These compounds may be found in a variety of natural ingredients and thus are not listed as individual compounds on R_x labels.

Acetyl-L-Carnitine (ALC) – is an amino acid important to cellular energy production and is the form of L-Carnitine capable of crossing the blood-brain barrier. ALC is vital to nerve/muscle communication, learning, alertness and problem solving. ALC promotes synthesis of acetylcholine (ACh) by donating acetyl groups and by activating the enzyme choline acetyltransferase (CAT) responsible for producing acetylcholine. Benefits of ALC supplementation include improvement in general metabolism of the nervous system, improvement in mental function by enhancing membrane stability, energy production, nerve transmission and enhanced membrane, nucleic acid and metabolic stability through decreasing free radical activity.



Chemical structure of Acetyl-L-Carnitine

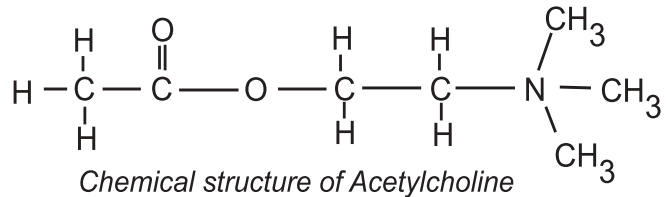

Chemical structure of Acetylcholine

Actein, cimicifugoside and formononetin – are triterpene glycosides and isoflavones found in the roots of black cohosh. These phytoestrogen compounds were tested in a randomized, double-blind study comparing their effects to those of estrogen and placebo. Study participants improved equally on phytoestrogens and estrogen while there was no improvement in the placebo control group.

Adrenal glandular (peptide hormone precursors, enzymes, natural lipids factors, soluble proteins, vitamins and minerals) – provides hormonal precursors and other nutrients. Adrenal exhaustion contributes to fatigue, immune dysfunction, hypoglycemia, allergies and arthritis. The biologically active components in adrenal glandular have immunomodulatory effects and anti-inflammatory properties, increase resistance to allergic reactions and infections, and provide adrenal strength for stress, allergies, muscle tone, blood-sugar balance, endurance, energy, blood circulation and sodium/water balance.

Alkaloids and flavonols – are effective anti-inflammatory and antioxidant agents promoting immunomodulation and lymphocytosis.

Allicin – has anti-inflammatory properties, inhibits the release of histamine and inhibits *Staphylococcus*, *Streptococcus*, *Bacillus*, *Brucella*, and *Vibrio* species, as well as *Candida albicans*. Allicin blocks oxidation-caused injury to pulmonary arterial cells, mainly by sparing the levels of intracellular glutathione, free radical scavenging, and by elimination of toxins.

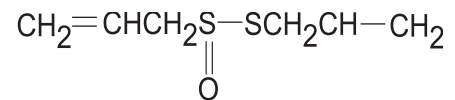

Allicin

Alpha-lipoic acid – lowers blood glucose levels by increasing its utilization in muscle and increasing insulin sensitivity. Alpha-lipoic acid also increases levels of reducing agents and regenerates other antioxidants in brain and nerves thereby providing antioxidant effects. Many clinical studies show promising effects in preventing nerve damage and polyneuropathy.

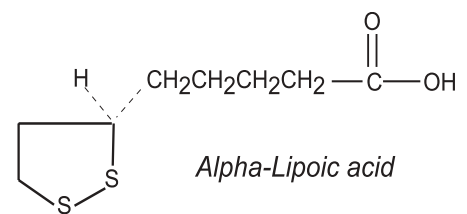

Alpha-Lipoic acid

Anthocyanosides – strengthen collagen in blood vessel walls, decrease intraocular pressure, improve capillary blood flow, prevent capillary fragility, stimulate the release of vasodilators, and decrease collagen breakdown. Anthocyanosides work with the intricate microcirculation in the eye to help prevent restricted blood flow and aid the flow of nutrients into, and metabolic wastes out of, ocular tissue.

Anthraquinone saccharides – help heal and prevent gastric ulcers by inactivating pepsin and by binding to parietal cells, thus interfering with hydrochloric acid release. These compounds also act as demulcents preventing irritants from reaching stomach lesions.

Antioxidants – are essential in both cancer prevention and treatment because of their ability to scavenge free radicals, reduce inflammation, assist in detoxification, regulate the immune system, and promote healing. Antioxidants aid in reducing stress-induced free radicals. Natural source beta-carotene and other flavonoids, Vitamin C, Vitamin E and alpha-lipoic acid have potent antioxidant activity.

Apigenin – is a flavonoid which binds to the same GABA (gamma-aminobutyric acid) receptors which have an affinity for benzodiazepines and barbiturates. Apigenin competitively inhibits the binding of flunitrazepam, a benzodiazepine. Apigenin has anxiolytic activity without incidence of sedation or muscle relaxation effects at doses similar to those used for classical benzo-diazepines.

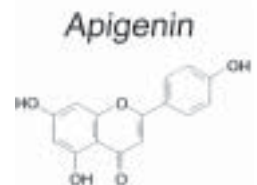

Apple polyphenols – prevent the attachment of *S. sobrinus* to tooth surfaces, thus inhibiting its production of glucans and other cariogenic factors. This antibacterial function prevents both tooth demineralization and dental caries. Polyphenols have also been shown in clinical studies to be effective in eliminating bad breath by inhibiting bacterial production of methyl-marcaptan by up to 80 percent.

Arbutin – a glycoside, has antiseptic and diuretic activity. It is metabolized to an antibacterial hydroquinone in the intestines, then linked to a hydrophilic molecule in the liver and carried via the blood to the kidney. There, the hydroquinone is released from its carrier and provides analgesia as well as antiseptis throughout the urinary tract.

Ascorbic acid – is the major dietary form of vitamin C. Vitamin C is a hexose derivative, similar in structure to glucose (high dietary sugars inhibit vitamin C activity by competing for binding sites). Vitamin C can scavenge tissue damaging reactive oxygen and nitrogen species. Ascorbic acid is an excellent reducing agent, acts as a cofactor in many biochemical reactions, inhibits lipid peroxidation and oxidative DNA and protein damage.

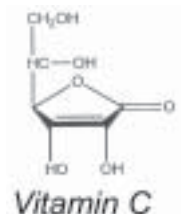

Biochanin, formononetin, diadzein and genistein – are isoflavones that have a high affinity for beta estrogen receptors predominant in heart, vascular, bone and bladder tissue. Some effects include protection against endocrine related cancers such as breast and prostate cancer, improved bladder sphincter tone and improvement in post-menopausal symptoms related to estrogen deficiency.

Bitter orange – is a thermogenic phytonutrient that increases metabolic rate utilizing adipose energy reserves and sparing lean muscle tissue.

Blood plasma – consists of approximately 50% albumin, 25% immunoglobulins (including alpha, beta, and gamma globulins), 5% fibrin, and 20% other proteins including haptoglobin, transferrin, and growth factors. More than 15% of the immunoglobulins present are Immunoglobulin G (IgG), which when consumed orally can increase the beneficial intestinal level of IgGs. An increase in intestinal IgG enhances enteropathogenic immunity resulting in elevated pathogen resistance. Ingestion of plasma also enhances enteric immunity, which prevents over stimulation of the systemic immune system.

Branched chain amino acids – including leucine, valine, and isoleucine regulate blood glucose levels and are also necessary for growth and repair of muscle tissue. They serve as building blocks for tissue proteins and as carbon precursors for the synthesis of tricarboxylic acid cycle intermediates, ketone bodies, and fat. They also provide carbon and nitrogen precursors for synthesis of other amino acids, such as alanine, glutamate, and glutamine for tissue repair.

Natural calcium sources – contain over 70 different major and trace minerals, many of which are chelated for optimal assimilation. Calcium can bind with oxalate in the intestine before it enters the bloodstream or urinary tract. Calcium exists in bone primarily in the form of hydroxyapatite ($\text{Ca}_{10}(\text{PO}_4)_6(\text{OH})_2$). Calcium concentration of dental plaque is an important determinant of the balance between enamel demineralization and remineralization. The rate of dissolution of hydroxyapatite is determined mostly by the level of saturation with calcium and phosphate ions in the tooth environment. Increasing calcium concentration disfavors demineralization and favors remineralization.



Co-enzyme Q₁₀ (ubiquinone) – is a lipophilic, water-insoluble nutrient involved in electron transport and energy production in mitochondrial membranes. CoQ₁₀ is of fundamental importance to cells with high metabolic demands. As with other antioxidant nutrients, CoQ₁₀ is subject to increased turnover as a result of stress or increased free radical load.

Immune cells, cardiac and skeletal muscle cells have a high metabolic rate and can easily exhaust co-enzyme Q₁₀ reserves.

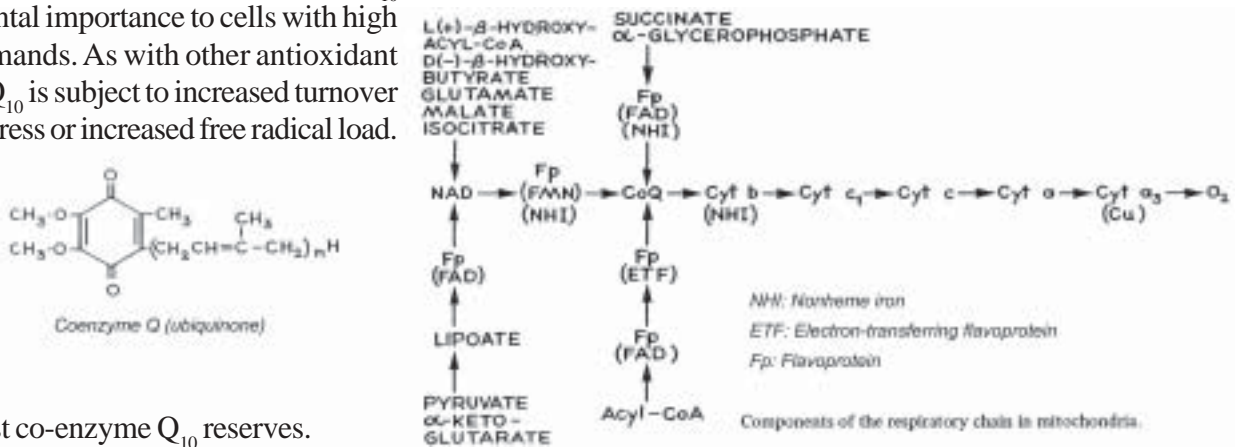

Colostrum – provides immune factors, such as Immunoglobulin G (IgG), which has anti-viral activity and helps to repair nucleic acids. Colostrum is also rich in casein, lactoferrin, alpha-lactalbumin, beta-lactoglobulin, insulin-like growth factors 1 and 2 (IGF-1 and IGF-2), transforming growth factor beta (TGFbeta) and epidermal growth factor (EGF).

Conjugated linoleic acid (CLA) – decreases white and brown adipose tissue, and helps regulate energy metabolism of skeletal muscle to promote lean body mass. CLA is thought to reduce body fat composition by inhibiting heparin-releasable lipoprotein lipase, which affects glucose metabolism in adipocytes causing less fat to be stored.

Curcuminoids – are polyphenolic compounds that have antioxidant, anticarcinogenic, and anti-inflammatory properties. Curcuminoid antioxidant activity includes its ability to increase glutathione peroxidase, glutathione reductase, glucose-6-phosphate dehydrogenase and catalase. The surmised anticarcinogenic activity of curcuminoids is thought to be its ability to inhibit angiogenesis, upregulate apoptosis, and interfere with specific signal transduction pathways that are necessary for tumor cell proliferation. Curcumin also assists in detoxification of drugs and chemicals by increasing phase II-metabolizing enzymes in the kidney and liver.

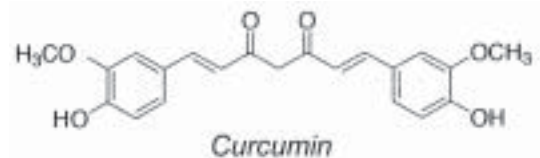

Capsaicin – relieves pain associated with arthritis by acting on sensory neurotransmitters leading to their depletion. VR1, the capsaicin receptor, is a sensory neuron-specific ion channel that serves as a detector of pain-producing

chemicals and physical stimuli. The response of VR1 to capsaicin is dynamically potentiated by extracellular protons within a pH range encountered during tissue acidosis associated with arthritis. Capsaicin has analgesic and anti-inflammatory actions and also acts as an antioxidant and an inhibitor of platelet adhesion.

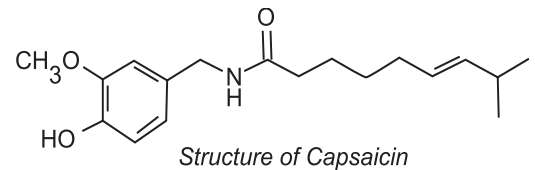

Carotenoids – such as lycopene are associated with a lower risk of lung cancer. The mechanism of this anticarcinogenic activity is not well understood, but may be due in part to antioxidant activity. Lycopene has the highest antioxidant activity of all the carotenoids. It has the ability to trap peroxy radicals, inhibit the oxidation of DNA, quench singlet oxygen, and inhibit lipid peroxidation. Lycopene may also stimulate gap junction communication between cells, suppress carcinogen-induced phosphorylation of regulatory proteins such as p53 and Rb antioncogenes, reduce cellular proliferation due to insulin-like growth factors, and stop cell division at the G0-G1 cell cycle phase.

Cetyl myristoleate – is a fatty acid ester comprised of the 16 carbon alcohol, cetyl alcohol, and the 14 carbon monounsaturated fatty acid cis-9 tetradecenoic acid (also known as myristoleic acid). Recent research has found that at least 87% of arthritic patients given cetyl myristoleate saw significant improvement in pain and mobility.

Certain cheeses – have unique properties which help prevent tooth decay. Cheese alkalinity buffers the acidity which predisposes to plaque. Also, cheese is a good gustatory stimulant of salivary flow which dilutes and clears sugars from the oral cavity. Cheese proteins inhibit demineralization and aid in remineralization, resulting in retained or regained enamel hardness.

Chlorophyll – is an effective natural tissue cleansing and detoxifying agent. Nutritional stress caused by poor diet, as well as environmental pollutants, leads to toxic buildup and improper adrenal function. Chlorophyll increases peristaltic action and cell growth, supports the immune system, modulates blood sugar and insulin secretion and thus decreases the need for production of adrenal stress hormones.

Collagen – is a protein made up of triple helix chains of amino acids (predominantly proline, glycine and lysine) interlaced with negatively charged proteoglycans. Consuming preformed collagen and proteoglycans provides complex subunits that can be directly incorporated into tissue proteoglycans and greatly augment and stimulate their manufacture. Collagen may also induce oral tolerance leading to a state of systemic hyporeponsiveness whereby autoantibodies destructive to joint tissue are not formed.

Diadzein and genistein – are estrogenic isoflavones. These phytoestrogen compounds have a structure similar to estrogen and provide estrogenic activity by binding to receptors. Phytoestrogens create a weak estrogenic effect and are not associated with the contraindications characteristic of estradiol and diethylstilbesterol.



DL-methionine – is a powerful antioxidant and urinary acidifier. Sulfates derived from methionine help create an acidic urine, which has been shown to prevent struvite formation and also decrease the ability of some bacteria to proliferate in the urinary tract.

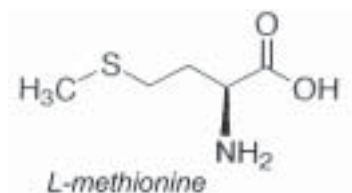

Docosahexaenoic acid (DHA) – a long-chain polyunsaturated omega-3 fatty acid, is incorporated into the phospholipid structure of all cell membranes, and is found in the highest concentration in gray matter and retinal tissue. DHA is necessary for proper elongation and formation of synapses essential for brain development and maintenance. If adequate supplies of DHA are present, the placenta preferentially absorbs it during fetal development in lieu of other available fatty acids. Due to cellular developmental needs of DHA, adequate supplementation helps to maintain optimum gestation periods, which lead to fully developed offspring. DHA is also beneficial for maternal skin and coat maintenance.

Dried pancreas and adrenal gland extracts – contain cell determinates of these glandular tissues which supply the genetic framework for formation of new glandular cells. Nutrients contained within specific tissues stimulate the corresponding tissue when consumed.

Enzymes such as amylase, protease, lipase, and cellulase- in non-thermally degraded ingredients and from supplementation, enhance digestive breakdown of ingested materials and spare exocrine pancreatic load.

Eudesmanolide along with germacranolide, taraxol, taraxerol, taraxasterol, stigmasterol, beta-stiosterol, and p-hydroxyphenylacetic acid – exert various nutraceutical effects including detoxification and diuresis. Studies have also shown inhibition of tumor necrosis factor-alpha (TNF-alpha) production by inhibiting interleukin-1 production. These compounds also exhibit free radical scavenging activity and reduction in the breakage of supercoiled DNA strands induced by non-site-specific and site-specific hydroxyl radicals.

Fatty acids – such as the omega-3 polyunsaturated fatty acid (PUFA), docosahexaenoic acid (DHA), modulate high levels of interleukin 1 (IL-1), a proinflammatory cytokine. Fatty acids also act as agonists for peroxisome proliferator-active receptors (PPARs) by binding to and transactivating PPARs. This leads to reduced gene expression, and thus reduced tumor growth.

Flavonoids, proanthocyanidins, terpenes, and flavoglycosides – enhance energy production, inhibit platelet aggregation, improve the transmission of nerve signals, improve free radical scavenging activity and increase circulation to the optic nerve.

Flavonoligans including silybin, isosilybin, dilydianin and silychristin – are antihepatotoxic and have antioxidant and membrane stabilizing properties. These compounds also inhibit the production of, and damage caused by, TNF-alpha and cause increases in transforming growth factor beta 1 and c-myc in hepatic tissue.

Galactomannan – is a highly viscous, soluble, dietary fiber found in the seeds of fenugreek. Galactomannan forms a gel in the stomach, slowing gastric emptying and thickening intestinal contents. This delays the absorption of glucose preventing spikes in postprandial blood sugar. Fenugreek seeds also contain the amino acid, 4 Hydroxyisoleucine, which may stimulate insulin secretion. Human studies have shown that fenugreek can help lower cholesterol and blood sugar levels in persons with moderate atherosclerosis and non-insulin-dependent diabetes. Double-blind trials have found that fenugreek helps improve blood sugar control in patients with insulin-dependent and non-insulin-dependent diabetes.

Gamma-linolenic acid (GLA) – is an 18 carbon, omega-6 polyunsaturated fatty acid with three unsaturations. GLA is converted to dihomogamma-linolenic acid (DGLA), a precursor to the 1-series prostaglandins, including PGE1. PGE1 suppresses the dermatologic inflammatory response by increasing intracellular cyclic AMP, which in turn reduces the release of lysosomal enzymes and polymorphonuclear leukocyte (PMN) chemotaxis and adherence to the endothelium. DGLA is also metabolized to 15-hydroxyl DGLA which blocks the conversion of arachidonic acid to proinflammatory leukotrienes. GLA is also anti-pruritic, restoring serum IFN-gamma levels.

Gingerols – are components of a mix of volatile oils and phenolic compounds. The ameliorative and anti-inflammatory effect is by inhibition of prostaglandin and leukotriene biosynthesis.

Ginosenosides – are active saponins. These compounds have a powerful hypoglycemic effect, possibly by slowing G/I transit time.. The fraction, DPG-3-2, has been found to stimulate insulin release from the pancreas of experimental animals. In health and in diabetes, ginosenosides lower the glycemic response after carbohydrate consumption. One controlled study with diabetic subjects demonstrated that ginosenosides lowered blood sugar 20% more than placebo pills.

Glucans – stimulate macrophages, monocytes, neutrophils, NK (natural killer) cells and LAK (lymphokine-activated killer) cells. This massive stimulation of immune cells induces the production of cytokines and nitric oxide (NO) in

macrophages, which are thought to result in antimicrobial and tumoricidal activity. Glucans also stimulate gut-associated lymphoid tissue (GALT), promoting cell migration to damaged tissue.

Glucosamine – is a component of virtually all tissues as a building block of connective tissue. Glucosamine is the foundation for cartilage proteoglycans and O-linked and N-linked glycosaminoglycans (GAGS). Glucosamine has several mechanisms of action including: enhancing production of glycosaminoglycans and proteoglycans, slowing the progression of cartilage lesions, reducing the generation of oxygen-free radicals by macrophages, inhibiting lysosomal enzymes, stabilizing cell membranes, and inhibiting interleukin-1-induced nitric oxide activity.

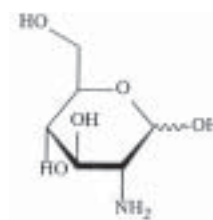

Glucosamine

Glucosides – improve learning and memory by stimulating nitric oxide synthesis. Nitric oxide is a vasodilator and thus enhances the delivery of blood and oxygen to tissues and facilitates the removal of toxins.

Glycoproteins – enhance production of T-cells in peripheral lymph nodes, protect against gamma-radiation and assist in detoxification of drugs and toxic chemicals, processes which are weakened with age.

Glycyrrhizan, flavanoids, triterpenoids, phytosterols, and coumarins – are anti-inflammatory and inhibit thrombin. Flavanoids encourage cellular differentiation, as well as mucus formation and secretion protecting the digestive tract.

Green-lipped mussel (GLM) – contains natural protein, vitamins, minerals, mucopolysaccharides, omega-3 fatty acids, and glycosaminoglycans. Several studies have shown green-lipped mussel inhibits inflammation. Although the precise mechanism of its anti-inflammatory actions are unknown, GLM contains a unique omega-3 fatty acid, eicosatetraenoic acid (ETA). ETA acts as a dual inhibitor of arachidonic acid oxygenation by both the lipoxygenase and cyclooxygenase pathways. Arachidonic acid metabolites perform a major role in the inflammatory sequence. Also, glycosaminoglycans are components of synovial fluid and cartilage matrix. Glycosaminoglycans may help inhibit degradative enzyme activity in cartilage, stimulate cartilage matrix production and help prevent thrombus, plaque and fibrin formation in the synovial and subchondral blood vessels. GLM does not affect platelet aggregation and is nongastrotoxic.

Gymnemic acids – have been shown to reduce hyperglycemia in both animal and human studies. Two animal studies in diabetic subjects revealed *Gymnema* extracts doubled the number of insulin secreting beta cells and returned blood glucose levels to almost normal. *Gymnema* also increases the activity of enzymes responsible for glucose uptake and utilization. Extracts have been found to inhibit epinephrine-induced hyperglycemia. In a controlled study, a standardized *Gymnema* extract was given as an adjunct to insulin to twenty-seven type 1 diabetics daily for 6-30 months. Thirty-seven others continued on insulin therapy alone and were tracked for 10-12 months. Insulin requirements were decreased by almost 50% and the average blood glucose decreased from 232 mg/dl to 152 mg/dl in the *Gymnema* group. The control group showed no significant decreases in blood glucose or insulin requirements over the length of the study. Twenty-two type 2 diabetics were administered *Gymnema* extract daily for 18-20 months in addition to their oral hypoglycemic medications. This group experienced significant decreases in average blood sugar and glycosylated hemoglobin (HbA1c), and an increase in pancreatic release of insulin. Medication dosages were decreased and five were able to discontinue oral hypoglycemic agents entirely.

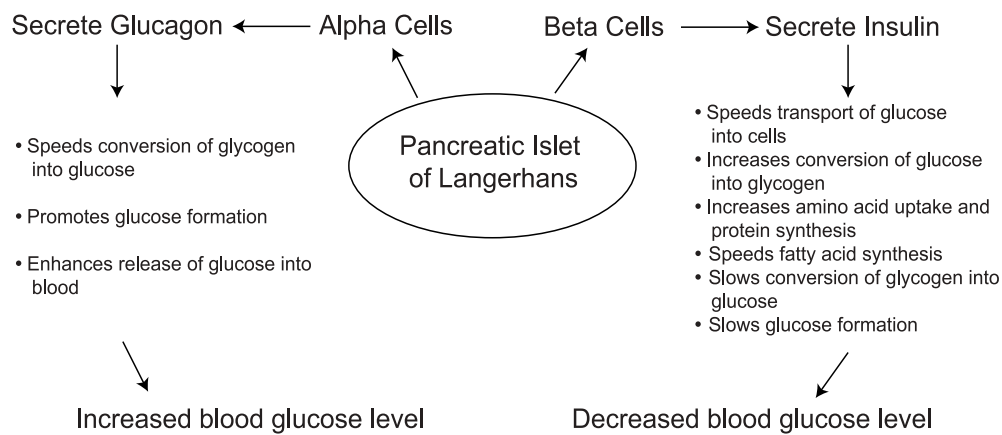

Harpagoside – has analgesic and anti-inflammatory properties. Harpagoside inhibits both cyclooxygenase and lipoxygenase arachidonic acid metabolic pathways.

Holothurin – is a sulfated triterpenoidal oligoglycoside, a bioflavonoid-like molecule. Holothurin helps block afferent sensory nerve conduction to reduce pain and contains high amounts of mucopolysaccharides and chondrocyte substance providing substrate for connective tissue. Several animal and human studies have shown a positive effect on arthritis (both rheumatoid arthritis and osteoarthritis) including reduction in inflammation, pain symptomatology and an increase in joint flexibility.

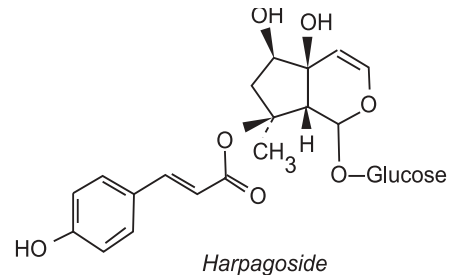

Hypericin – is used eight to one over standard antidepressants in Germany. Hypericin and pseudohypericin, dianthryrone derivatives, act by inhibiting the uptake of serotonin, norepinephrine and dopamine.

Immunoglobulins such as Immunoglobulin G (IgG) – from milk and plasma fractions, have anti-viral activity, and help repair damaged nuclear and mitochondrial nucleic acids.

Lactoglobulins – including beta-lactoglobulin and alpha-lactoglobulin from whey have glutathione antioxidant activity and exert antimicrobial and immunodulatory effects.

Lactones – improve concentration, memory and reaction time and produce physical and mental relaxation, a feeling of well being, sedation and sleep enhancement.

Lentinin – stimulates maturation and differentiation of immune system cells. More than 300 studies and dozens of long-term clinical trials establish the effectiveness in immune stimulation and modulation.

L-Glutamine – is a precursor for protein synthesis and an intermediate in a large number of metabolic pathways. As the amino acid with the highest concentration in the blood stream, L-glutamine serves as a nitrogen transporter between various tissues, creating natural anabolic nitrogen balance.

Ligans – provide high gum mucilage that soothes, moistens, and protects the intestinal mucosa, buffers excess acid, and helps to prevent flatulence and stool odor.

Liver – contains elements responsible for the development and maturation of hepatic tissue. Nutrients contained within specific tissues stimulate the corresponding tissue when consumed by providing immunomodulatory effects, adrogenic/estrogenic properties, as well as other rejuvenating factors.

L-Arginine – promotes the release of growth hormones. It also regulates glucose utilization by stimulating the release of glucagons and insulin. L-Arginine enhances the immune system by increasing the number of neutrophils and IgG antibody levels.

L-Carnitine – is part of the enzyme carnitine acyltransferase I, which converts long chain fatty acyl-CoA derivatives into O-acylcarnitine for transportation across mitochondria. Once inside the mitochondria, L-carnitine is released allowing the fatty acyl-CoA derivatives to be used in beta-oxidation reactions that burn excess fat, and prevents it from being stored as adipose tissue. L-carnitine is also a building block of lean muscle tissue.

L-Leucine – is a branched-chain amino acid that assists in regulating blood glucose levels because it is purely ketogenic. Upon degradation, neither of its derivatives acetyl-CoA nor acetoacetate are convertible to glucose. L-leucine is also necessary for growth and repair of muscle tissue.

L-Taurine - is an important dietary non-protein amino acid produced as the end-product of L-cysteine metabolism. It is found free-roaming in intracellular cytoplasm, and is necessary for proper development of the brain and retina in the fetus. Adequate taurine levels in the mother also increase prolactin, necessary for milk production.

Lutein (C₄₀H₅₆O₂) – is a member of the xanthophyll class of carotenoids, which are fat-soluble yellowish pigments found in some plants, algae and photosynthetic bacteria. It is a polyisoprenoid containing 40 carbon atoms and cyclic structures at each end of its conjugated chains. Although not synthesized *in situ*, lutein is found in the macula of the retina as well as the crystalline lens. Lutein acts as an antioxidant, protecting cell membrane lipids from the damaging effects of free radicals.

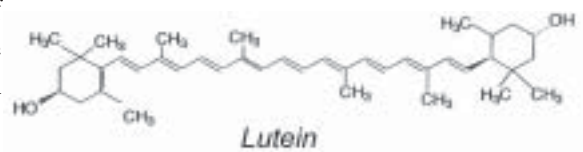

Magnesium – inhibits the formation of calcium-oxalate crystals in urine by competing with calcium for oxalate.

Mannose – is a carbohydrate that adheres to bacterial receptors on the bladder lining, inhibiting bacterial adhesion.

Medium chain triglycerides (MCTs) – decrease adipose tissue and increase fat oxidation, while having a sparing effect on fat-free tissue mass, thus encouraging muscle tissue growth and repair. MCTs are rapidly and directly absorbed in the large intestine for energy use, thus preventing direct deposition into adipose tissue. MCTs also increase calorie consuming thermogenesis.

Methylsulfonylmethane (MSM) – a metabolite of dimethyl sulfoxide (DMSO), is one of the most abundant biochemicals in tissue. Analgesic effects of MSM are due to vasodilation, an increase in blood supply, reductions in inflammation and muscle spasm, increased cell membrane permeability, softening of scar tissue, and inhibition of neural pain impulses. MSM may also help the repair and maintenance of cartilage.

Methylated cellulose – forms a non-fermentable mucilaginous mass which absorbs water to create bulk, causing stimulation of digestive motility.

N-Acetylcysteine (NAC) – is the N-acetyl derivative of the amino acid L-cysteine. NAC is an excellent source of sulfhydryl (SH) groups and is converted into metabolites capable of stimulating glutathione synthesis, thus promoting detoxification and free radical scavenging. The acetyl-substituted amino group makes the molecule more stable against oxidation and serves as a particularly effective antioxidant.

Omega-3 fatty acids – play critical roles in cell and organelle membrane structure and in a wide array of physiological processes through eicosanoid modulation. As structural membrane components and precursors to signaling molecules such as prostaglandins, omega-3 fatty acids can, in effect, control health. Omega-3s improve blood lipid and fatty acid profiles, lower plasma triacylglycerol concentrations and LDL cholesterol levels, and block excessive and erratic sodium and calcium currents in the heart. Docosahexaenoic acid (DHA) is the primary building block of the brain where high concentrations of DHA are found in the cerebral cortex. DHA plays a significant role in cerebral development and is required for maintenance of normal brain function in adults. Adequate levels of DHA are necessary for proper neurotransmissions.

Phosphatidylcholine – is a functional and structural element present in all biological membranes, a precursor to acetylcholine, and plays a rate-limiting role in the activation of numerous membrane-located enzymes, such as superoxidase dismutase and glutathione, which are antioxidants protecting cell membranes from damage by reactive oxygen species.

Proanthocyanidins – prevent adherence of both antibiotic-resistant and sensitive *E. coli* strains to the bladder lining, allowing bacteria to be flushed from the bladder upon urination and preventing establishment of urinary tract infection. Proanthocyanidins prevent the pilli on the outside of the bacteria from forming properly, resulting in their inability to adhere to the bladder lining.

Quercetin – is a flavanoid that prevents the release of histamine by inhibiting degranulation of mast cells, basophils and neutrophils through cell membrane stabilization. It also decreases leukotrine formation and lipid peroxidation.

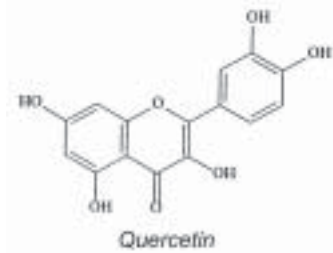

Thymic substance – increases neutrophilic, CD3 and CD4 cellular functions and salivary IgA levels. Thymic substance also normalizes the function and quantity of T-cells. Nutrients contained within specific tissues stimulate the corresponding tissue when eaten. Therefore, consumption of thymic substance aids in thymic cell growth, function and repair, aiding immune response.

Triterpenoids – promote relaxation, enhance and improve memory and treat mental and physical fatigue with mild tranquilizing, anti-stress and anti-anxiety actions via the enhancement of cholinergic mechanisms.

Thiosulphonates – are organo-sulphur compounds. Thiosulphonates, such as allicin, ajoene, diallyl sulfide (DAS), diallyl disulfide (DADS), S-allylmercapto cysteine and S-methylmercapto cysteine provide beneficial pancreatic activities. Thiosulphonates are believed to augment detoxification through free-radical scavenging as well as combine with thiamine to promote insulin secretion.

Trona mineral salts – have antibacterial properties and are highly effective natural agents in removing dental plaque. Trona alkaline minerals are known to inhibit the oral pathogen, *Streptococcus sobrinus* by 68 percent.

Valepotriates and valeric acid – weakly bind the same receptors in the brain as benzodiazepines, and *in vitro* they displace benzodiazepines at receptor sites.

Vanadyl sulphate – improves glucose control in non-insulin-dependent diabetes mellitus primarily by augmentation of peripheral glucose utilization. Studies have shown oral doses of vanadyl sulfate do not alter insulin sensitivity in non-diabetics but improve both hepatic and skeletal muscle insulin sensitivity in non-insulin-dependent diabetics.

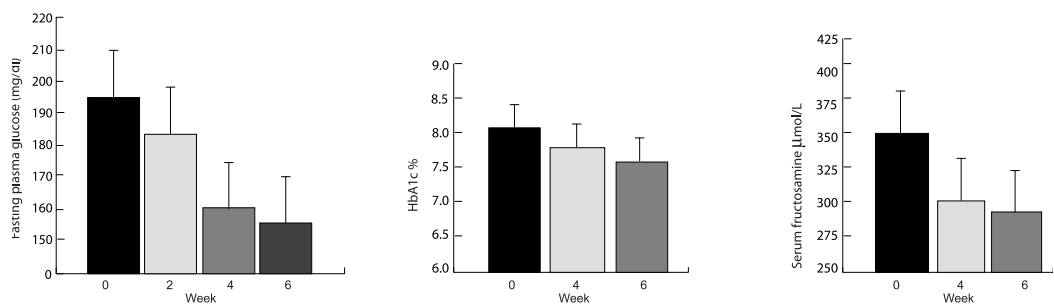

Values of fasting glucose, HbA1c and fructosamine during 6-week trial of 11 Type II diabetic patients receiving vanadyl sulfate.

Vitamin B₆ (pyridoxine) – is a cofactor in the conversion of glyoxalate, a precursor of oxalate, to glycine, thus reducing oxalate formation. Vitamin B₆ is used to treat hyperoxaluria when dietary reduction of oxalate and calcium supplementation are not effective in the prevention of calcium oxalate calculi.

Whey proteins – contain the amino acids cysteine, glutamate and glycine, which are nutritional precursors to glutathione. Glutathione is an important intracellular antioxidant, particularly within immune cells. The ability of lymphocytes to regenerate glutathione has a direct effect on their ability to respond to antigenic stimuli.

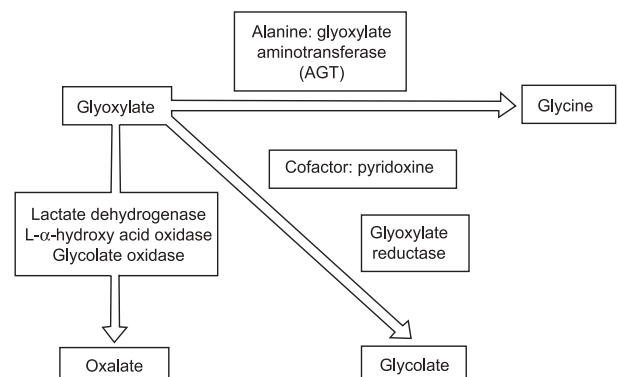

Pyridoxine as a cofactor of glyoxalate

Xylan – is a hydrophilic polysaccharide that absorbs water in the large intestine, increasing stool bulk and stimulating peristalsis to enhance defecation.

Xylitol –is the only known cariostatic (cavity-inhibiting) sugar. It is a unique, natural carbohydrate containing five carbon atoms instead of the six contained in sweeteners or sugars (such as fructose and glucose) and thus oral bacteria are unable to metabolize it. For example, *Streptococcus mutans* adsorbs on the surface of the teeth. When the pH of this bacteria’s plaque milieu falls below 5.5, calcium and phosphate salts start to dissolve from the surface of the enamel. Dental caries begin to form and the tooth weakens. Birch bark sugars impede this pathogenesis with the density of acid-producing lactobacilli and streptococci falling as much as 90 percent.

Nutrition-First Packaging

Oxygen and light are the enemy of fragile nutrients. Auto-oxidation and photo-oxidation “corrode” nutrients and also convert them to free radicals, which in an escalating chain reaction turn healthful food into a potpourri of toxins. (See Figure 28.)

WR_x incorporates state-of-the-art packaging technology including oxygen- and light-barrier film and vacuum evacuation.

This is accomplished by a synergistic proprietary formulation of natural vitamins, enzymes, phyto-extracts, flavanoids, phenolics, and organic acid chelators. Independent testing has shown antioxidant activity exceeding that of synthetics such as BHA, BHT, TBHQ and propyl gallate without attendant toxicities.

Method Of Use

WR_x are first of all highly nutritious, bioavailable, archetypal, natural foods. Aside from therapeutic benefits, patients will experience relief from the burden of food processing toxins, and the ongoing metabolization of foods they are not genetically adapted to. It is like a “nutritional homecoming” with the “joy” manifest in the exceptional palatability and health results.

WR_x are completely balanced according to NRC standards but go far beyond these minimums due to the

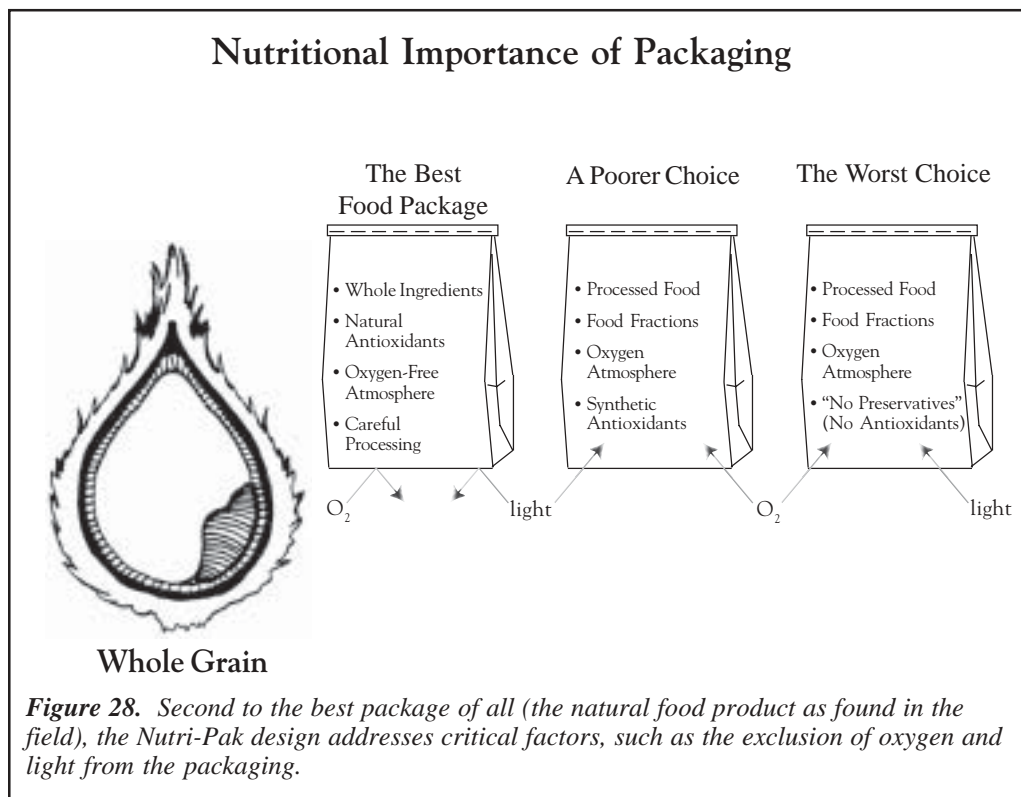

inherent increased value of non-heat-degraded natural ingredients.

As such, WR_x can be fed exclusively (stipulations follow) in the same sense as any other commercially balanced pet food.

How To Feed

WR_x are a highly concentrated food and should be introduced slowly. Crumble a small amount on top of regular food to begin. WR_x can be fed as is, or mixed with warm water (below 110°F) to rehydrate. Let stand for 10-15 minutes if rehydrating. Dry or moistened, WR_x can be fed as singular meals or mixed or top-dressed on other foods.

If problems arise, discontinue for a day and reintroduce at lower levels. Once tolerated, increase the portion

incrementally over a two-week period until the following dosage is achieved.

Dosage

Unlike pharmaceuticals that are very dose-sensitive and fraught with potential complications, WR_x are extremely safe.

Use 1/3 cup per 10 lbs. body weight per day, combined with 1/2 recommended daily feedings of high quality meat-based maintenance foods such as Wysong dry, canned or frozen.

Continue at this level for 3-4 weeks for best effect. Then the WR_x may be occasionally offered as above, or as a solo meal (1/3 cup/10 lbs) or top-dressed as a supplement in lesser amounts.

Client budgetary considerations will perhaps dictate use in larger animals. The principle to remember is that a precise “dose” is not the key element. Even small amounts of WR_x as treats and top-dressing will bring benefits. More is better, but inability to feed at recommended dosage levels should not preclude the feeding of lesser amounts.

Anorexia

The high palatability of WR_x may solve anorexia if offered free choice. If not, rehydrate as above into a “paste” consistency and spoon onto palate. For enteric feeding, blend the selected WR_x with water and Wysong PDG™ (predigested nutrition) to the desired consistency.

Cachexia

Recommended feeding levels can be doubled if weight gain is desired. The amino acid profile in WR_x base ingredients is strongly anabolic.

Other Foods

Wysong Diets (dry, canned, frozen, non-heat degraded) are excellent alternative meals to WR_x, or base foods to which WR_x can be supplemented. Variety is important to any feeding regimen if optimal health is the goal. (See Adjunct Nutrition.)

Supplements

Although WR_x are as nutritionally concentrated as possible, additional specific supplementation can bring added benefits. The accompanying chart indicates the encapsulated Nutraceutical formulation matching each WR_x. To increase nutraceutical effects, coat the capsules in butter and force, or place in the center of a moistened bolus of WR_x or Wysong Peanut Butter Plus™.

The following supplements are particularly beneficial as nutritional boosters to heat processed dry and canned foods. They are designed to invigorate such foods with raw natural food elements.

Biotics™ – micronutrient, enzyme, probiotic enhancement.

Pet Inoculant™ – concentrated probiotics

EFA™ – antioxidant protected omega 3, 6, 9 fatty acids

Adjunct Nutrition for WR_x

| <u>WR_x Diet</u> | <u>Adjunct Diets</u> | <u>Adjunct Nutraceuticals</u> |
|----------------------------|--|--|
| Adivase™ | Archetype™ Diets, All Meat™ Diets, Tundra™ Diets | Anaplex™ |
| Adrevar™ | Archetype™ Diets, All Meat™ Diets, Tundra™ Diets | |
| Allercin™ | Archetype™ Diets, All Meat™ Diets, Tundra™ Diets | Wysong EFA™ Supplements, Immulyn™ |
| Anacline™ | Archetype™ Diets, All Meat™ Diets, Tundra™ Diets, Growth dry and canned diets | Anaplex, PDG™ Biotic Supplement |
| Cardiril™ | Archetype™ Diets, All Meat™ Diets, Tundra™ Diets, Senior dry and canned (for canines), Geriatr™ dry and canned (for felines) | Carvasol™, Wysong EFA™ Supplements |
| Dentacet™ | Archetype™ Diets, All Meat™ Diets, Tundra™ Diets | Dentatreat™, Mega C™ |
| Dermutec™ | Archetype™ Diets, All Meat™ Diets, Tundra™ Diets, Synorgon™ dry (for canines), Vitality™ dry (for felines) | Wysong EFA™ Supplements, Immulyn™, Spectrox™ |

Adjunct Nutrition for WR_x (cont'd)

| <u>WR_x Diet</u> | <u>Adjunct Diets</u> | <u>Adjunct Nutraceuticals</u> |
|----------------------------|--|---|
| Diabid™ | Archetype™ Diets, All Meat™ Diets, Tundra™ Diets | Carboprin™, Panzyme™, Wysong EFA™ Supplements, Wysong Biotic™ Supplements |
| Digesome™ | Archetype™ Diets, All Meat™ Diets, Tundra™ Diets | Pepzhac™, Panzyme™, Wysong EFA™ Supplements, Pet Inoculant™, Wysong Biotic™ Supplements |
| Estroxil™ | Archetype™ Diets, All Meat™ Diets, Tundra™ Diets | Estrolog™, Menstruphen™, Wysong EFA™ Supplements, Wysong Biotic™ Supplements |
| Gerodyne™ | Archetype™ Diets, All Meat™ Diets, Tundra™ Diets, Senior dry and canned (for canines), Geriatrux™ dry and canned (for felines) | Carvasol™, Spectrox™, Wysong EFA™ Supplements, PDG™ |
| Gestain™ | Archetype™ Diets, All Meat™ Diets, Tundra™ Diets, Growth dry and canned (for canines), Nurture™ dry (for felines) | Pet Inoculant™, Mother's Milk™, Wysong EFA™ Supplements |
| Heparone™ | Archetype™ Diets, All Meat™ Diets, Tundra™ Diets | Hepticene™, Spectrox™, Wysong Biotic™ Supplements |
| Immuncef™ | Archetype™ Diets, All Meat™ Diets, Tundra™ Diets, Synorgon™ dry (for canines), Vitality™ dry (for felines) | Wysong EFA™ Supplements, Pet Inoculant™, Immuly™, Spectrox™, Pancidrim™ |
| Lithonel™ | Archetype™ Diets, All Meat™ Diets, Tundra™ Diets | Fiber-Min EFA™, Wysong Biotic™ Supplements |
| Neomentin™ | Archetype™ Diets, All Meat™ Diets, Tundra™ Diets, Synorgon™ dry (for canines), Vitality™ dry (for felines) | Pet Inoculant™, Wysong EFA™ Supplements, Immuly™, Spectrox™, Salad™ |
| Nephreon™ | Archetype™ Diets, All Meat™ Diets, Tundra™ Diets, Senior dry and canned (for canines), Geriatrux™ dry and canned (for felines) | Nephurol™, Wysong EFA™ Supplements |
| Neuropril™ | Archetype™ Diets, All Meat™ Diets, Tundra™ Diets | Neuridone™, Spectrox™, Wysong EFA™ Supplements |
| Ocusone™ | Archetype™ Diets, All Meat™ Diets, Tundra™ Diets | Ophid™, Spectrox™, Wysong EFA™ Supplements |
| Osseron™ | Archetype™ Diets, All Meat™ Diets, Tundra™ Diets | Arthegic™, Glucosamine Complex™, Contifin™, Wysong EFA™ Supplements |
| Panadime™ | Archetype™ Diets, All Meat™ Diets, Tundra™ Diets | Panzyme™, Wysong Biotic™ Supplements |
| Pathovert™ | Archetype™ Diets, All Meat™ Diets, Tundra™ Diets, Synorgon™ dry (for canines), Vitality™ dry (for felines) | Wysong EFA™ Supplements, Immuly™, Spectrox™, Pancidrim™ |
| Pedivax™ | Archetype™ Diets, All Meat™ Diets, Tundra™ Diets, Growth dry (for canines), Nurture™ dry (for felines) | Wysong EFA™ Supplements, Pet Inoculant™, Mother's Milk™, PDG™ |
| Respityl™ | Archetype™ Diets, All Meat™ Diets, Tundra™ Diets, Synorgon™ dry (for canines), Vitality™ dry (for felines) | Wysong EFA™ Supplements, Immuly™, Spectrox™, Pancidrim™ |

Adjunct Nutrition for WR_x (cont'd)

| <u>WR_x Diet</u> | <u>Adjunct Diets</u> | <u>Adjunct Nutraceuticals</u> |
|----------------------------|--|---|
| Sedadul™ | Archetype™ Diets, All Meat™ Diets, Tundra™ Diets | Somniquil™, Wysong EFA™ Supplements |
| Streseper™ | Archetype™ Diets, All Meat™ Diets, Tundra™ Diets, Growth dry (for canines), Nurture™ dry (for felines) | Wysong EFA™ Supplements, Pet Inoculant™, Mother's Milk™, PDG™, Anaplex™ |
| Struvatrol™ | Archetype™ Diets, All Meat™ Diets, Tundra™ Diets, Growth dry (for canines), Uretic™ dry (for felines) | Biotic pH™ |
| Uratar™ | Archetype™ Diets, All Meat™ Diets, Tundra™ Diets | Nephurol™ |
| Vermiden™ | Archetype™ Diets, All Meat™ Diets, Tundra™ Diets Pancidrim™ | Biotic supplements™, Pet Inoculant™, Colex™, Pancidrim™ |

General Cautions

Any food, natural or not, can potentially trigger allergic reaction. If slowly introducing WR_x as a top-dress to normal feeding results in digestive or other disturbances, withdraw for several days and reintroduce. If concomitant signs reappear, the client should be instructed to discontinue and seek alternative approaches by consulting with the veterinarian or Wysong technical staff.

Safe Handling

Wash working surfaces, utensils, and hands after feeding. Excess food should be refrigerated for the next feeding or discarded. Keep inner bag sealed once opened. Although WR_x are quite stable at room temperature, store in refrigerator or freezer to retain maximum nutraceutical value. Keep from direct heat or sunlight.

References:

Best D. Solution Near on *E. coli* Crisis. *Prepared Foods*. 1993.; Bjorck L. Antibacterial Effect of lactoperoxidase system of sychrotrophic bacteria in milk. *J Dairy Res*. 45:109. 1978.; Bjork L, et al. The antibacterial activity of lactoperoxidase system in milk against Pseudomonads and other gram negative bacteria. *Applied Microbiol*. 30:195. 1975.; Bowles BL, et al. Inhibition of foodborne bacterial pathogens by naturally occurring food additives. *J Food Sci*. 18(1998)101-112. 1998.; Branan AL, et al. Phenolic Compounds. 2nd ed. *Antimicrobials in Foods*. Marcel Dekker, Inc. New York. 37-74. 1993.; Buchanan RL, et al. Foodborne disease significance of *Escherichia coli* O157:H7 and other enterohemorrhagic *E. coli*. *Food Technol*. 51(10):69-75. 1997.; Bullen JJ, et al. Iron-binding proteins in milk and resistance to *Escherichia coli* infection in infants. *Br. Med. J*. 1:69. 1972.; Ceylan E, et al. Thermal inactivities of *Escherichia coli* O157:H7 in ground beef patties in the presence of garlic. Food Safety Consortium Meeting, Afton, OK. Oct. 17-19, pp. 148-157. 1999a.; Dobrin RS, et al. The antibacterial activity of lactoferrin. *Fed. Proc*. 34:1044. 1975.; Donovan JL, et al. Phenolic composition and antioxidant activity of prunes and prune juice (*Prunus domestica*). *J Agric Food Chem*. 46:1247-1252. 1998.; Doyle JD, et al. *Escherichia coli* O157:H7. *Food Microbiology Fundamentals and Frontiers*. ASM Press, Washington, D.C., pp. 171-191. 1997.; Doyle MP, et al. *Staphylococcus aureus*. *Food Microbiology Fundamentals and Frontiers*. ASM Press, Washington, D.C. pp 353-375. 1997.; Doyle MP, et al. *Salmonella* Species. *Food Microbiology Fundamentals and Frontiers*. ASM Press, Washington, D.C., 129-152. 1997.; Duffy G, et al. The effect of a competitive microflora, pH and temperature in the growth kinetics of *Escherichia coli* O157:H7. *Food Microbiology*. 16:299-307.; Gerson C, et al. The lactoperoxidase system functions in bacterial clearance of airways. *Am J Respir Cell Mol Biol* 22:665-671. 2000.; Jay MJ. *Modern Food Microbiology*, 3rd ed. Von Nostrand Reinhold Company, New York, pp.353-375. 1986.; Korhonen H. Antimicrobial factors in bovine colostrums. *Science and Agric Soc*. 49:34. 1977.; Lindsay RC, Food Additives. In. Fennema, O.R. ed *Food Chemistry*. 3rd ed. Marcel Dekker, Inc. New York. 78-81. 1996.; Martinez RJ, et al. Sequential metabolic expression of the lethal process in human serum treated *E. coli*: rate of lysozyme. *Infect Immun*. 28:735. 1980.; Nakatani N, et al. Identification, quantitative determination, and antioxidative activities of chlorogenic acid isomers in prune (*Prunus domestica* L.) *J Agric Food Chem*. 48(11):5512-5516. 2000.; Paul KG, et al. The isolation and some liganding properties of lactoperoxidase. *FEBS Lett*. 110:200. 1980.; Petrides PE. Molecular genetics of peroxidase deficiency. *J Mol Med*. 76:688-698. 1998.; Raccach M. The antimicrobial activity of phenolic antioxidants in foods: a review. *J Food Safety*, 6:141-170. 1984.; Rahman MS, et al. Natural antimicrobials for food preservation. *Handbook of Food Preservation*. Marcel Dekker, Inc. New York. pp. 285-308. 1993.; Reiter B. Review of nonspecific antimicrobial factors in colostrum. *Ann Rec Vet*. 9:205. 1978.; Rice-Evans CA, et al. Antioxidant properties of phenolic compounds. *Trends in Plant Science* 2(4):152-159. 1997.; Spik G, et al. Bacteriostatics of a milk-sensitive strain of *Escherichia coli* by immunoglobulins and iron binding proteins in association. *Immunology*. 35:663.; Taubman MA. Immunoglobulins of human dental plaque. *Arch Oral Biol*. 19:439. 1974.; Tenovuo J. Formation of the bacterial inhibitor, hypothiocyanite ion, by cell-bound lactoperoxidase. *Caries Res*. 13:137. 1979.; Tenovuo J, et al. Antibacterial activity of lactoperoxidase adsorbed by human salivary sediment and hydroxyapatite. *Caries Res*. 11:257. 1977.; Tenovuo J, et al. Immobilized lactoperoxidase as a biologically active and stable form of an antimicrobial enzyme. *Arch Oral Biol*. 26:309. 1981.; Tenovuo J, et al. Inhibition of dental plaque production by the salivary lactoperoxidase antimicrobial system. *Infect Immun*. 34:208. 1981.